

Standard ball screws



Miniature ball screws



Rolled ball screws

Ø	Pitch (travel per revolution)						
	5	10	16	20	25	40	50
16	●	●	●				
20	●	●		●			
25	●	●			●		
32	●	●		●			
40	●	●		●		●	
50		●		●			●
63		●		●			
80		●		●			

Miniature ball screws

Ø	Pitch (travel per revolution)						Nut
	1	2	2.5	4	5		
6	●					flanged	
8	●	●	●			flanged	
10		●		●		flanged/cylinder	
12		●		●	●	flanged/cylinder	
14		●				flanged/cylinder	



L1377

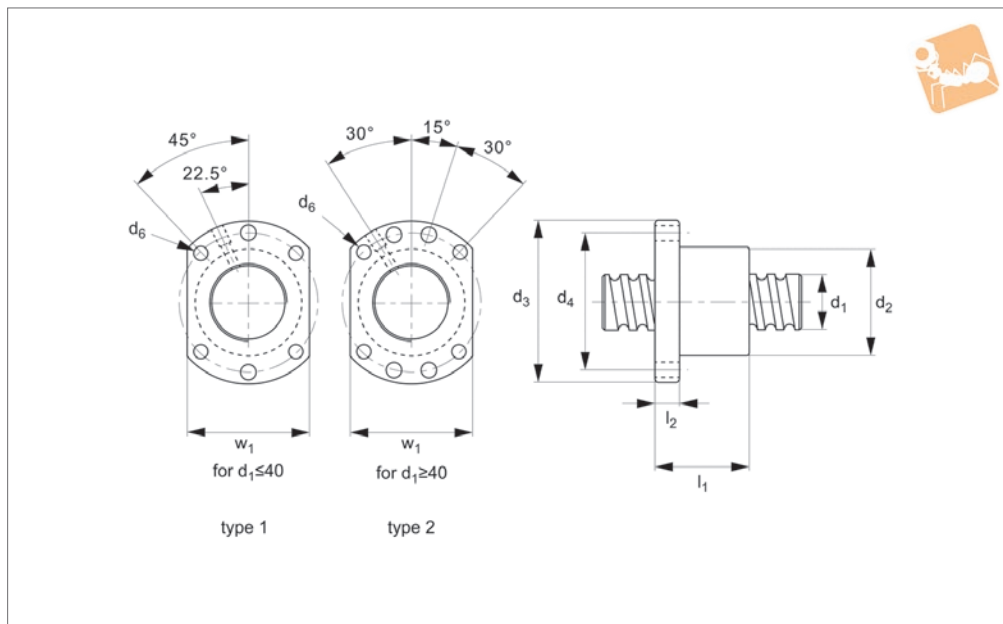

Material

Black chrome steel (16MnCr5 or 100Cr6), with Vulkolan seals. Precision class C7.

Technical Notes

Axial play for 5mm pitch = 0,05mm; for 10mm pitch = 0,10mm; for multi-starts = 0,20mm.

Preload max. 5% of max. dynamic load. For axial run-out, concentricity and paral-

lelism figures see technical pages. With lubrication and fixing holes. For use with ball screws no. L1377. Anti corrosion finish consists of a thin layer of black chrome and produces good resistance to wear, and a protective effect against corrosion. Layer thickness 2-10µm.

Tips

For easy mounting of the ball screw nuts

see the nut bracket - part L1377.

Important Notes

Fit ball nut to screw using the sleeve provided. Offer up the ball nut to the screw and slide carefully on. Do not remove the ball nut from the sleeve provided - the ball bearings can come loose rendering the ball nut unusable.

Order No.	Type	Pitch	d ₁ for screw	l ₁	l ₂	d ₂ tol. G6	d ₃ ±0.15	d ₄ ±0.15	d ₅ for	d ₆	w ₁ ±0.15	Ball dia.	Dyn. load C kN max.	Static load C ₀ kN max.
L1377.16-05	Type 1	5	16	45	10	28	48	38	M 6	5.5	40	3.175	13.53	29.92
L1377.20-05	Type 1	5	20	51	10	36	58	47	M 6	6.6	44	3.175	15.21	38.00
L1377.25-05	Type 1	5	25	51	10	40	62	51	M 6	6.6	48	3.175	16.91	48.09
L1377.25-10	Type 1	10	25	80	12	40	62	51	M 6	6.6	48	4.762	28.96	71.54
L1377.32-05	Type 1	5	32	52	12	50	80	65	M 6	9.0	62	3.175	18.85	62.21
L1377.32-10	Type 1	10	32	85	12	50	80	65	M 6	9.0	62	6.350	47.12	119.72
L1377.40-05	Type 2	5	40	55	14	63	93	78	M 8	9.0	70	3.175	20.69	78.34
L1377.40-10	Type 2	10	40	88	14	63	93	78	M 8	9.0	70	6.340	52.95	152.00



Ø 16 Ball Screws- Anti Corrosion rolled

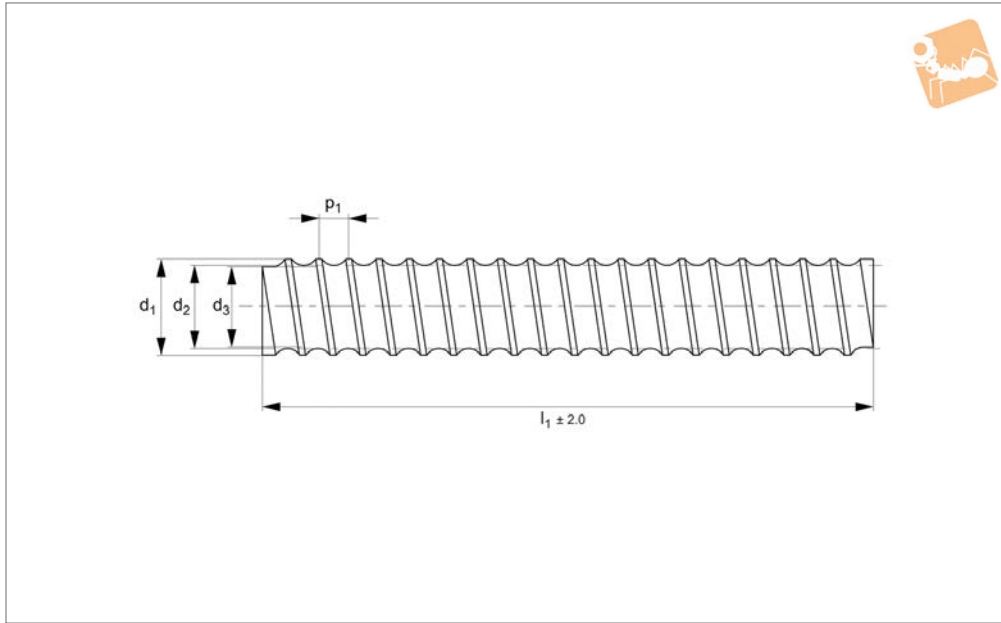
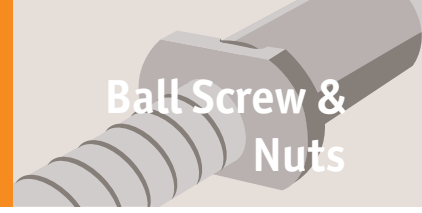

L1377.16

BALL SCREW & NUTS

Material

Black chrome steel (CF53 or C55R), induction hardened to 60 HRC ±2, polished.

Technical Notes

Gothic profile with a 5 or 10mm lead. Tolerance T7 - 50µ/300mm. Shorter lengths or longer lengths up to a maximum of 6000mm available.

For ball screw nuts see part L1377.

For end screw machining to suit ball screw support units see relevant ball screw supports (L1388-L1406). End machining on request. Anti corrosion finish consists of a thin layer of black chrome and produces good resistance to wear, and a protective effect against corrosion. Layer

thickness 2µm to 10µm.

Important Notes

Ensure the ball nut can be fitted to the ball screw after machining. Do not remove the ball nut from the sleeve prior to installation - the balls come free rendering the ball nut unusable.

Order No.	Screw dia. x lead	d ₁	l ₁	d ₂	d ₃	Lead w ₁	Mass moment of inertia kg·m ²	Weight kg
L1377.16-05-0500	16x 5	17.08	500	16	13.9	5	4,45x10 ⁻⁵	0.71
L1377.16-05-0600	16x 5	17.08	600	16	13.9	5	4,45x10 ⁻⁵	0.845
L1377.16-05-0800	16x 5	17.08	800	16	13.9	5	4,45x10 ⁻⁵	1.13
L1377.16-05-1000	16x 5	17.08	1000	16	13.9	5	4,45x10 ⁻⁵	1.41
L1377.16-05-1500	16x 5	17.08	1500	16	13.9	5	4,45x10 ⁻⁵	2.12
L1377.16-05-2000	16x 5	17.08	2000	16	13.9	5	4,45x10 ⁻⁵	2.82
L1377.16-05-2500	16x 5	17.08	2500	16	13.9	5	4,45x10 ⁻⁵	3.53
L1377.16-05-3000	16x 5	17.08	3000	16	13.9	5	4,45x10 ⁻⁵	4.23



L1377.20

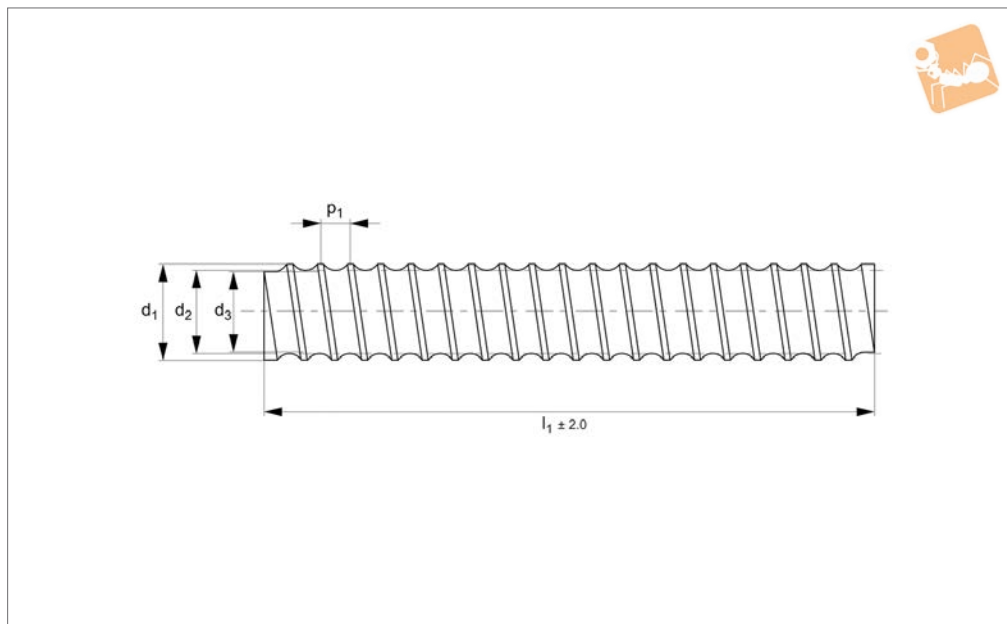

Material

Black chrome steel (CF53 or C55R), induction hardened to 60 HRC ±2, polished.

Technical Notes

Gothic profile with a 5,20 or 50mm lead. Tolerance T7 - 50µ/300mm. Shorter lengths or longer lengths up to a maximum of 6000mm available. For ball screw nuts see part L1377.

For end screw machining to suit ball screw support units see relevant ball screw supports (L1388-L1406). End machining on request.

Also available as a left hand thread for 5mm pitch. Anti corrosion finish consists of a thin layer of black chrome and produces good resistance to wear, and a protective effect against corrosion. Layer

thickness 2µm to 10µm.

Important Notes

Ensure the ball nut can be fitted to the ball screw after machining. Do not remove the ball nut from the sleeve prior to installation - the balls come free rendering the ball nut unusable.

Order No.	Screw dia. x lead	d ₁	l ₁	d ₂	d ₃	Lead w ₁	Mass moment of inertia kg·m ²	Weight kg
L1377.20-05-0500	20x 5	21.08	500	20	17.9	5	1,12x10 ⁻⁴	1.18
L1377.20-05-0600	20x 5	21.08	600	20	17.9	5	1,12x10 ⁻⁴	1.41
L1377.20-05-0800	20x 5	21.08	800	20	17.9	5	1,12x10 ⁻⁴	1.88
L1377.20-05-1000	20x 5	21.08	1000	20	17.9	5	1,12x10 ⁻⁴	2.35
L1377.20-05-1500	20x 5	21.08	1500	20	17.9	5	1,12x10 ⁻⁴	3.53
L1377.20-05-2000	20x 5	21.08	2000	20	17.9	5	1,12x10 ⁻⁴	4.70
L1377.20-05-2500	20x 5	21.08	2500	20	17.9	5	1,12x10 ⁻⁴	5.88
L1377.20-05-3000	20x 5	21.08	3000	20	17.9	5	1,12x10 ⁻⁴	7.05



Ø 25 Ball Screws - Anti Corrosion rolled

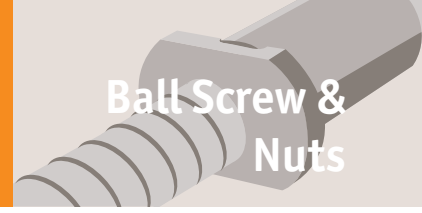

Ball Screw & Nuts

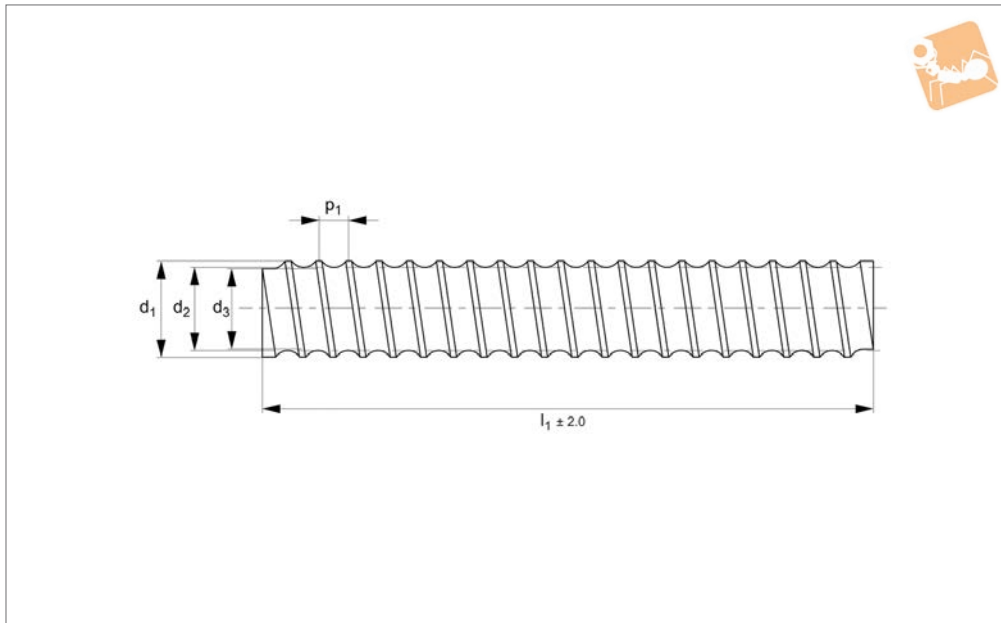

L1377.25

BALL SCREW & NUTS

Material

Black chrome steel (CF53 or C55R), induction hardened to 60 HRC ± 2 , polished.

Technical Notes

Gothic profile with a 5, 10 or 2mm lead. Tolerance T7 - 50 μ /300mm. Shorter lengths or longer lengths up to a maximum of 6000mm available.

For ball screw nuts see part L1377.

For end screw machining to suit ball screw support units see relevant ball screw supports (L1388-L1406). End machining on request. Anti corrosion finish consists of a thin layer of black chrome and produces good resistance to wear, and a protective effect against corrosion. Layer

thickness 2 μ m to 10 μ m.

Important Notes

Ensure the ball nut can be fitted to the ball screw after machining. Do not remove the ball nut from the sleeve prior to installation - the balls come free rendering the ball nut unusable.

Order No.	Screw dia. x lead	d ₁	l ₁	d ₂	d ₃	Lead w ₁	Mass moment of inertia kg·m ²	Weight kg
L1377.25-05-0500	25x 5	26.08	500	25	22.9	5	2,62x10 ⁻⁴	1.80
L1377.25-05-0600	25x 5	26.08	600	25	22.9	5	2,62x10 ⁻⁴	2.15
L1377.25-05-0800	25x 5	26.08	800	25	22.9	5	2,62x10 ⁻⁴	2.87
L1377.25-05-1000	25x 5	26.08	1000	25	22.9	5	2,62x10 ⁻⁴	3.59
L1377.25-05-1500	25x 5	26.08	1500	25	22.9	5	2,62x10 ⁻⁴	5.39
L1377.25-05-2000	25x 5	26.08	2000	25	22.9	5	2,62x10 ⁻⁴	7.18
L1377.25-05-2500	25x 5	26.08	2500	25	22.9	5	2,62x10 ⁻⁴	8.98
L1377.25-05-3000	25x 5	26.08	3000	25	22.9	5	2,62x10 ⁻⁴	10.77
L1377.25-05-3500	25x 5	26.08	3500	25	22.9	5	2,62x10 ⁻⁴	2.87
L1377.25-05-4000	25x 5	26.08	4000	25	22.9	5	2,62x10 ⁻⁴	3.59
L1377.25-05-4500	25x 5	26.08	4500	25	22.9	5	2,62x10 ⁻⁴	5.39
L1377.25-05-5000	25x 5	26.08	5000	25	22.9	5	2,62x10 ⁻⁴	7.18
L1377.25-05-5500	25x 5	26.08	5500	25	22.9	5	2,62x10 ⁻⁴	8.98
L1377.25-05-6000	25x 5	26.08	6000	25	22.9	5	2,62x10 ⁻⁴	10.77
L1377.25-10-0500	25x10	27.15	500	25	20.8	10	2,94x10 ⁻⁴	1.91
L1377.25-10-0600	25x10	27.15	600	25	20.8	10	2,94x10 ⁻⁴	2.29
L1377.25-10-0800	25x10	27.15	800	25	20.8	10	2,94x10 ⁻⁴	3.05
L1377.25-10-1000	25x10	27.15	1000	25	20.8	10	2,94x10 ⁻⁴	3.81
L1377.25-10-1500	25x10	27.15	1500	25	20.8	10	2,94x10 ⁻⁴	5.72
L1377.25-10-2000	25x10	27.15	2000	25	20.8	10	2,94x10 ⁻⁴	7.62
L1377.25-10-2500	25x10	27.15	2500	25	20.8	10	2,94x10 ⁻⁴	9.53
L1377.25-10-3000	25x10	27.15	3000	25	20.8	10	2,94x10 ⁻⁴	11.43
L1377.25-10-3500	25x10	26.08	3500	25	22.9	10	2,62x10 ⁻⁴	2.87
L1377.25-10-4000	25x10	26.08	4000	25	22.9	10	2,62x10 ⁻⁴	3.59
L1377.25-10-4500	25x10	26.08	4500	25	22.9	10	2,62x10 ⁻⁴	5.39
L1377.25-10-5000	25x10	26.08	5000	25	22.9	10	2,62x10 ⁻⁴	7.18
L1377.25-10-5500	25x10	26.08	5500	25	22.9	10	2,62x10 ⁻⁴	8.98
L1377.25-10-6000	25x10	26.08	6000	25	22.9	10	2,62x10 ⁻⁴	10.77



L1377.32

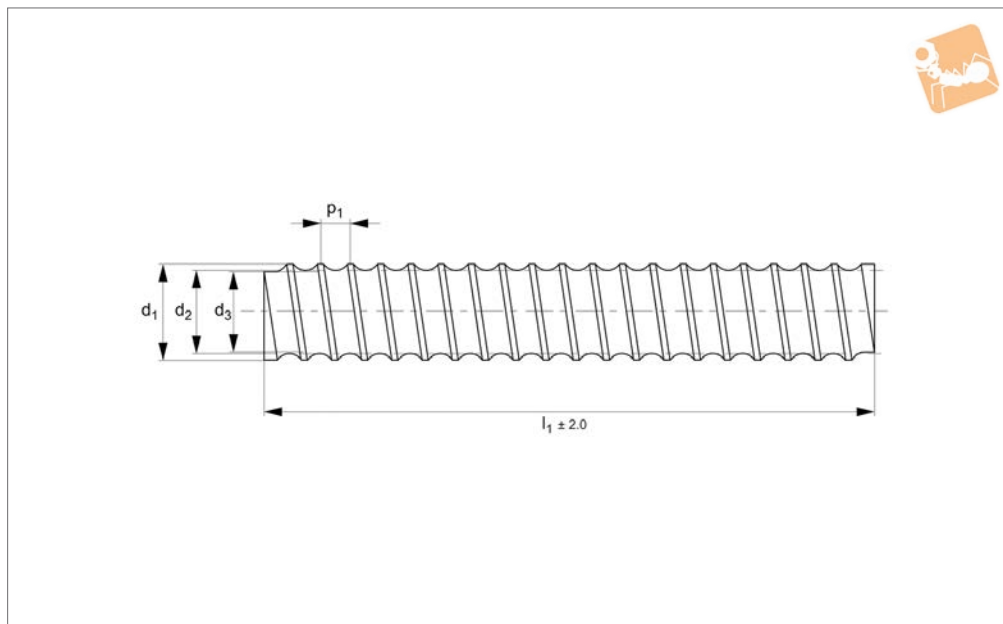

Material

Black chrome steel (CF53 or C55R), induction hardened to 60 HRC ±2, polished.

Technical Notes

Gothic profile with a 5,10,20 or 40mm lead.

Tolerance T7 - 50µ/300mm. Shorter lengths or longer lengths up to a maximum of 6000mm available.

For ball screw nuts see part L1377.

For end screw machining to suit ball screw support units see relevant ball screw supports (L1388-L1406). End machining on request.

Also available as a left hand thread for 5mm pitch. Anti corrosion finish consists of a thin layer of black chrome and produces good resistance to wear, and a

protective effect against corrosion. Layer thickness 2µm to 10µm.

Important Notes

Ensure the ball nut can be fitted to the ball screw after machining. Do not remove the ball nut from the sleeve prior to installation - the balls come free rendering the ball nut unusable.

Order No.	Screw dia. x lead	d ₁	l ₁	d ₂	d ₃	Lead w ₁	Mass moment of inertia kg·m ²	Weight kg
L1377.32-05-0500	32x 5	33.08	500	32	29.9	5	7,25x10 ⁻⁴	2.99
L1377.32-05-0600	32x 5	33.08	600	32	29.9	5	7,25x10 ⁻⁴	3.59
L1377.32-05-0800	32x 5	33.08	800	32	29.9	5	7,25x10 ⁻⁴	4.78
L1377.32-05-1000	32x 5	33.08	1000	32	29.9	5	7,25x10 ⁻⁴	5.98
L1377.32-05-1500	32x 5	33.08	1500	32	29.9	5	7,25x10 ⁻⁴	8.97
L1377.32-05-2000	32x 5	33.08	2000	32	29.9	5	7,25x10 ⁻⁴	11.96
L1377.32-05-2500	32x 5	33.08	2500	32	29.9	5	7,25x10 ⁻⁴	14.95
L1377.32-05-3000	32x 5	33.08	3000	32	29.9	5	7,25x10 ⁻⁴	17.94
L1377.32-05-3500	32x 5	33.08	3500	32	29.9	5	7,25x10 ⁻⁴	4.78
L1377.32-05-4000	32x 5	33.08	4000	32	29.9	5	7,25x10 ⁻⁴	5.98
L1377.32-05-4500	32x 5	33.08	4500	32	29.9	5	7,25x10 ⁻⁴	8.97
L1377.32-05-5000	32x 5	33.08	5000	32	29.9	5	7,25x10 ⁻⁴	11.96
L1377.32-05-5500	32x 5	33.08	5500	32	29.9	5	7,25x10 ⁻⁴	14.95
L1377.32-05-6000	32x 5	33.08	6000	32	29.9	5	7,25x10 ⁻⁴	14.95
L1377.32-10-0500	32x10	34.15	500	32	27.8	10	7,69x10 ⁻⁴	3.08
L1377.32-10-0600	32x10	34.15	600	32	27.8	10	7,69x10 ⁻⁴	3.70
L1377.32-10-0800	32x10	34.15	800	32	27.8	10	7,69x10 ⁻⁴	4.93
L1377.32-10-1000	32x10	34.15	1000	32	27.8	10	7,69x10 ⁻⁴	6.16
L1377.32-10-1500	32x10	34.15	1500	32	27.8	10	7,69x10 ⁻⁴	9.24
L1377.32-10-2000	32x10	34.15	2000	32	27.8	10	7,69x10 ⁻⁴	12.32
L1377.32-10-2500	32x10	34.15	2500	32	27.8	10	7,69x10 ⁻⁴	15.40
L1377.32-10-3000	32x10	34.15	3000	32	27.8	10	7,69x10 ⁻⁴	18.48
L1377.32-10-3500	32x10	33.08	3500	32	29.9	10	7,25x10 ⁻⁴	4.78
L1377.32-10-4000	32x10	33.08	4000	32	29.9	10	7,25x10 ⁻⁴	5.98
L1377.32-10-4500	32x10	33.08	4500	32	29.9	10	7,25x10 ⁻⁴	8.97
L1377.32-10-5000	32x10	33.08	5000	32	29.9	10	7,25x10 ⁻⁴	11.96
L1377.32-10-5500	32x10	33.08	5500	32	29.9	10	7,25x10 ⁻⁴	14.95
L1377.32-10-6000	32x10	33.08	6000	32	29.9	10	7,25x10 ⁻⁴	14.95



Ø 40 Ball Screws - Anti Corrosion rolled

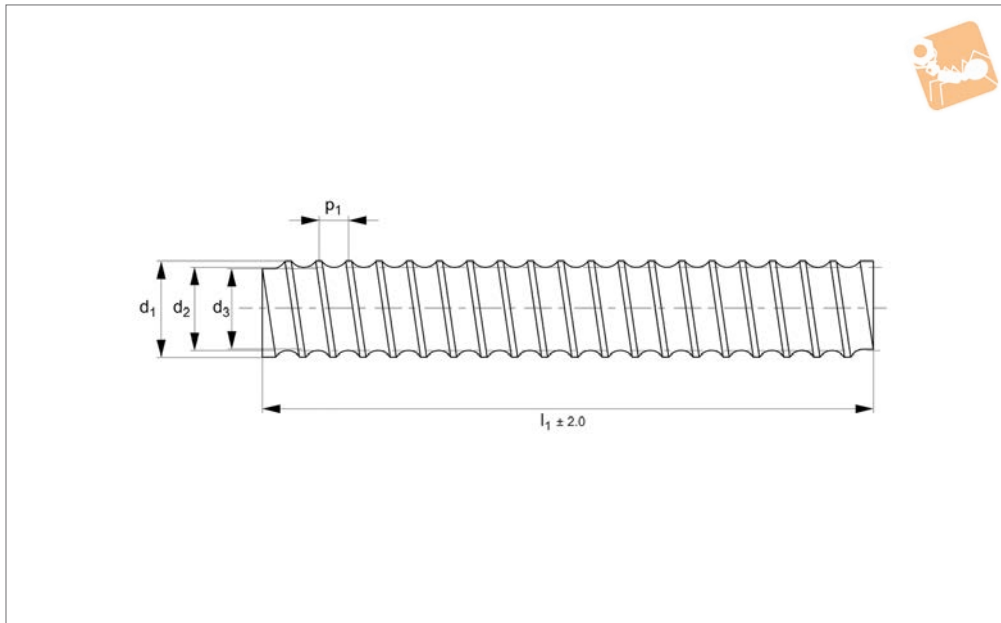
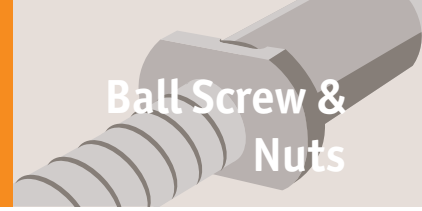

L1377.40

BALL SCREW & NUTS

Material

Black chrome steel (CF53 or C55R), induction hardened to 60 HRC ±2, polished.

Technical Notes

Gothic profile with a 5, 10 or 20mm lead. Tolerance T7 - 50µ/300mm. Shorter lengths or longer lengths up to a maximum of 6000mm available.

For ball screw nuts see part L1377.

For end screw machining to suit ball screw support units see relevant ball screw supports (L1388-L1406). End machining on request. Anti corrosion finish consists of a thin layer of black chrome and produces good resistance to wear, and a protective effect against corrosion. Layer

thickness 2µm to 10µm.

Important Notes

Ensure the ball nut can be fitted to the ball screw after machining. Do not remove the ball nut from the sleeve prior to installation - the balls come free rendering the ball nut unusable.

Order No.	Screw dia. x lead	d ₁	l ₁	d ₂	d ₃	Lead w ₁	Mass moment of inertia kg·m ²	Weight kg
L1377.40-05-0500	40x 5	41.08	500	40	37.9	5	1,81x10 ⁻³	4.72
L1377.40-05-0600	40x 5	41.08	600	40	37.9	5	1,81x10 ⁻³	5.66
L1377.40-05-0800	40x 5	41.08	800	40	37.9	5	1,81x10 ⁻³	7.55
L1377.40-05-1000	40x 5	41.08	1000	40	37.9	5	1,81x10 ⁻³	9.44
L1377.40-05-1500	40x 5	41.08	1500	40	37.9	5	1,81x10 ⁻³	14.16
L1377.40-05-2000	40x 5	41.08	2000	40	37.9	5	1,81x10 ⁻³	18.88
L1377.40-05-2500	40x 5	41.08	2500	40	37.9	5	1,81x10 ⁻³	23.60
L1377.40-05-3000	40x 5	41.08	3000	40	37.9	5	1,81x10 ⁻³	28.32
L1377.40-05-3500	40x 5	41.08	3500	40	37.9	5	1,81x10 ⁻³	7.55
L1377.40-05-4000	40x 5	41.08	4000	40	37.9	5	1,81x10 ⁻³	9.44
L1377.40-05-4500	40x 5	41.08	4500	40	37.9	5	1,81x10 ⁻³	14.16
L1377.40-05-5000	40x 5	41.08	5000	40	37.9	5	1,81x10 ⁻³	18.88
L1377.40-05-5500	40x 5	41.08	5500	40	37.9	5	1,81x10 ⁻³	23.60
L1377.40-05-6000	40x 5	41.08	6000	40	37.9	5	1,81x10 ⁻³	28.32
L1377.40-10-0500	40x10	42.15	500	40	35.8	10	1,66x10 ⁻³	4.51
L1377.40-10-0600	40x10	42.15	600	40	35.8	10	1,66x10 ⁻³	5.41
L1377.40-10-0800	40x10	42.15	800	40	35.8	10	1,66x10 ⁻³	7.22
L1377.40-10-1000	40x10	42.15	1000	40	35.8	10	1,66x10 ⁻³	9.02
L1377.40-10-1500	40x10	42.15	1500	40	35.8	10	1,66x10 ⁻³	13.53
L1377.40-10-2000	40x10	42.15	2000	40	35.8	10	1,66x10 ⁻³	18.04
L1377.40-10-2500	40x10	42.15	2500	40	35.8	10	1,66x10 ⁻³	22.55
L1377.40-10-3000	40x10	42.15	3000	40	35.8	10	1,66x10 ⁻³	27.06
L1377.40-10-3500	40x10	41.08	3500	40	37.9	10	1,81x10 ⁻³	7.55
L1377.40-10-4000	40x10	41.08	4000	40	37.9	10	1,81x10 ⁻³	9.44
L1377.40-10-4500	40x10	41.08	4500	40	37.9	10	1,81x10 ⁻³	14.16
L1377.40-10-5000	40x10	41.08	5000	40	37.9	10	1,81x10 ⁻³	18.88
L1377.40-10-5500	40x10	41.08	5500	40	37.9	10	1,81x10 ⁻³	23.60
L1377.40-10-6000	40x10	41.08	6000	40	37.9	10	1,81x10 ⁻³	28.32



When selecting a ball screw some of the main factors to consider are:

- Maximum required travel speed
- Maximum axial compression (buckling load)
- Method of support of the ball screws
- Type of unit required, flanged, cylindrical etc.

In general it is best to support the ball screws with our ball screw support units (L1388 to L1406) with a fixed end (generally where the motor is mounted) and a floating (support) end. The support units are selected to suit the loads likely to be required, the size of the ball screw (especially its core diameter) and the type of mounting required. Details of the machining required for each end of the ball screw are shown in the bearing mounts technical section.

The data table for the ball screws show the diameter, the lead of the ball screw (i.e. how far the nut travels for one complete revolution of the screw) as well as the mass moment of inertia (also known as the rotational moment of inertia) - this is the extent to which an object resists rotational acceleration about its axis.

Maximum speeds and buckling load data are shown in the technical pages.

When using a ball screw the ambient temperature should not exceed +80°C.

During assembly, the parallel alignment of the guides should be ensure.

The details on the concentricity of the ball nuts to the ball screws are shown on the technical pages. For linear guideways for use with ball screws please see our part numbers L1016 etc.

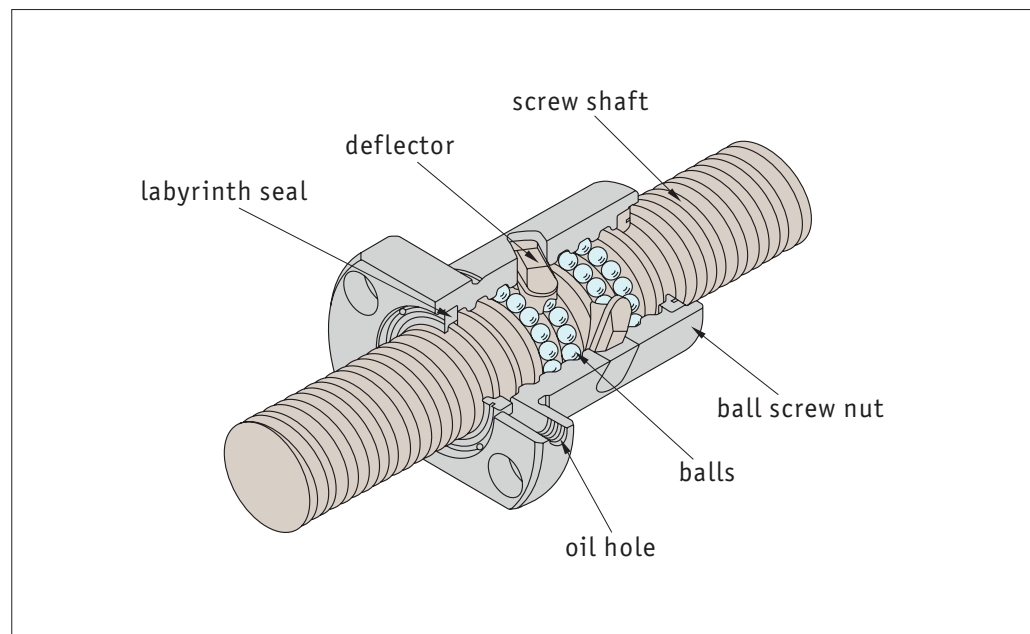

Lubrication - the ball screws must be adequately lubricated. This is dependent on load, speed, motion sequence and temperature. Do not use lubricants containing Mo/So or graphite.



In general, the ball nut is already on the ball screw and should not be removed. If you need to machine the ball screw, then the plastic mounting sleeve should be used to retain the ball bearings whilst the nut is removed.

Mounting the nut on the screw

Sometimes ball screws are delivered with a separate ball nut. When mounting the nut on to the screw take care as if done incorrectly the ball bearings may come off the ball nut.

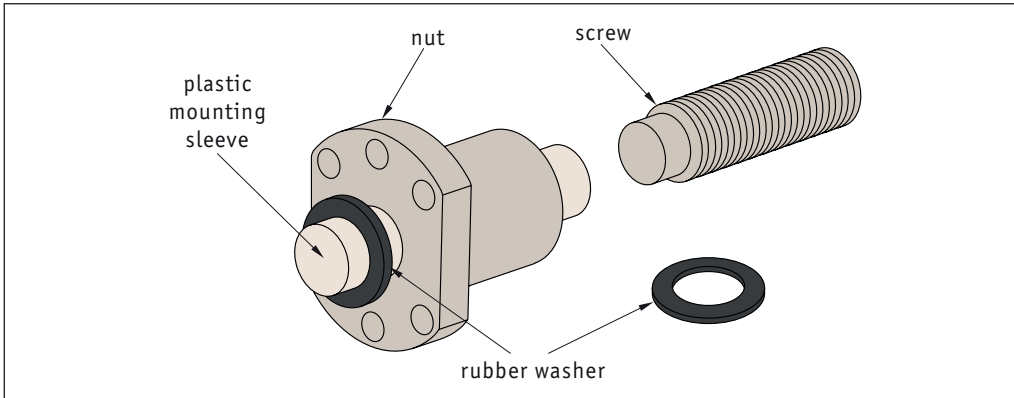

Ball nuts should be mounted only with the help of a plastic mounting sleeve (delivered with the nut). The start of the thread should be aligned so that the seal and the internal parts of the nut are not damaged.

1. Remove the rubber washer from one side of the sleeve. Push on the nut with the sleeve on the end of the screw. Press the sleeve against the start of the screw thread.
2. Screw the nut onto the thread using a slight axial pressure, then screw the nut on for its entire length.
3. Remove the mounting sleeve only when the nut is completely threaded on to the screw.
4. Lock the nut on to the screw (to prevent any unscrewing) using an O ring or similar - whilst installing the system.

If the balls do unfortunately escape...

1. Pick them up (the nut is only compatible with the original balls). The load capacity can still be achieved if one or two balls are missing.
2. Carefully clean all parts, use the sleeve as a mounting jig and replace the balls.
3. Start with the lowest circuit. Insert the balls into the nut circuit - the sleeve prevents the balls from falling out again.
4. Do not place the balls in the empty circuit located between the two deflectors.

If you have any technical queries please call **0333 207 4498**.