



### L1016 Linear guideways

Linear guideways are widely used throughout industry for heavy-duty and precise applications.

### Precision high load rails

The use of steel balls and the design of the carriages and guideways mean that the rails can accept very heavy loads and significant moment loads. Our rails have circular as opposed to friction coefficient, lower driving resistance, lower wear and lower energy consumption.

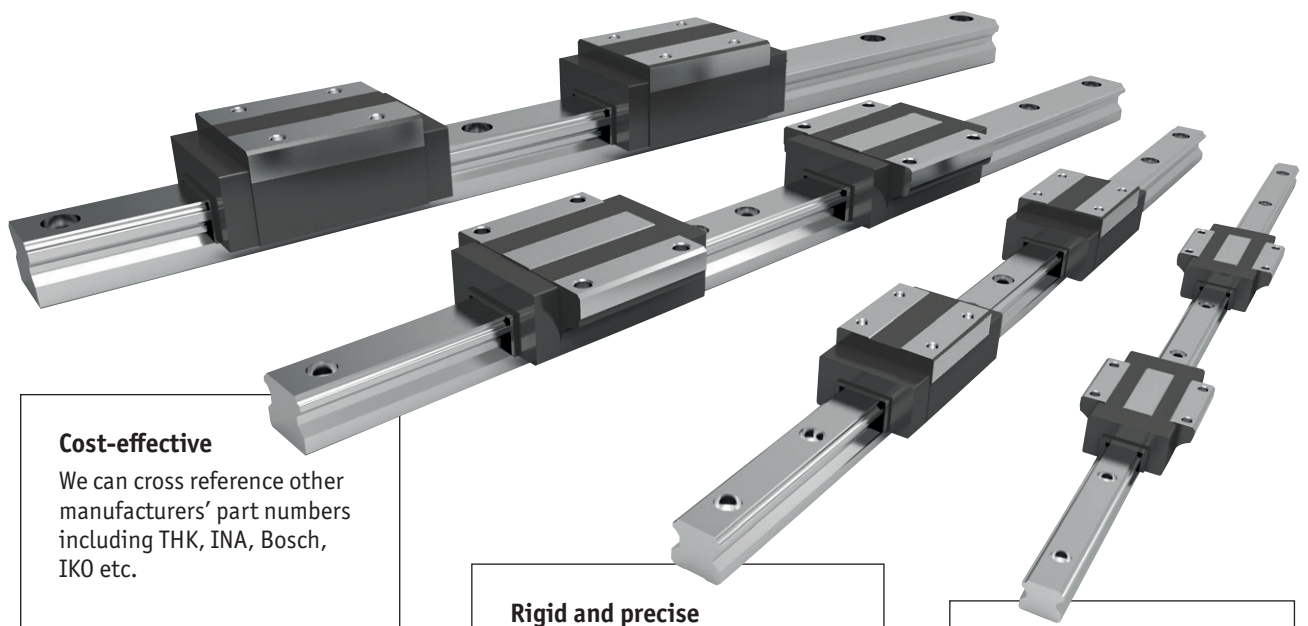

#### Cost-effective

We can cross reference other manufacturers' part numbers including THK, INA, Bosch, IKO etc.

#### Rigid and precise

- High load rating.
- High moment load capacity.

#### Stocked

7 rail profiles ready for same day despatch. Lengths up to 4 metres.

### Rail sizes

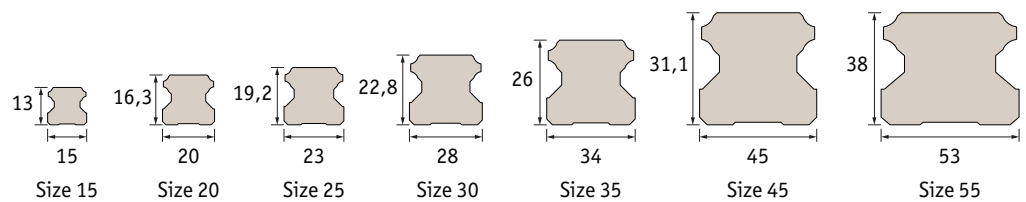

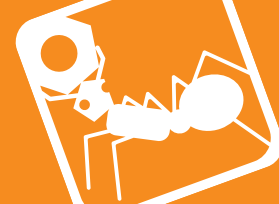

## L1017.F

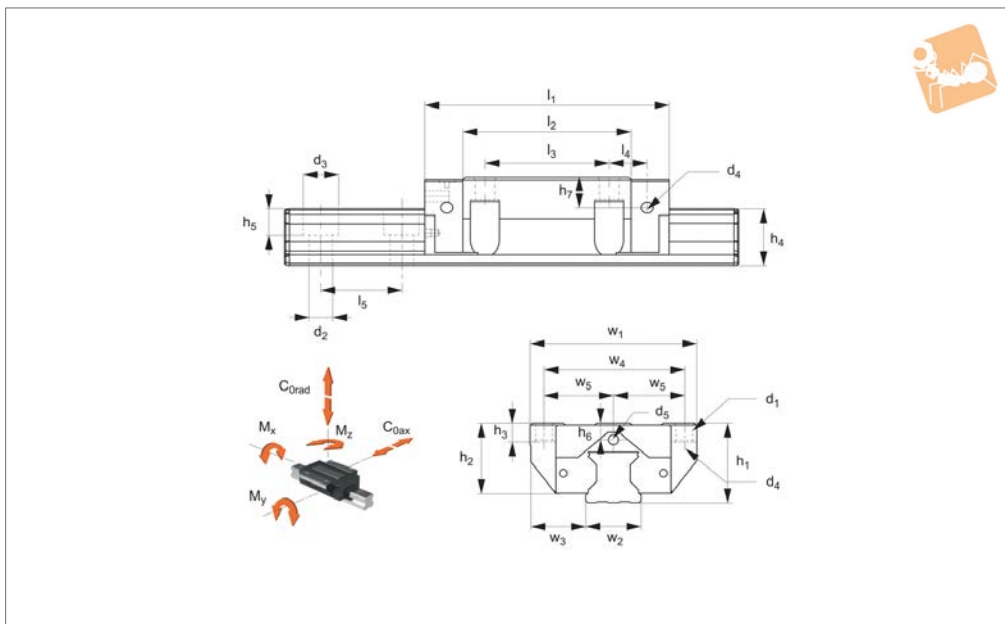

### Material

Hardened and ground steel.

### Technical Notes

Needle roller linear guideways can take significantly higher loads than the same size standard (ball) linear guideways. Select the size and number of carriages to

suit the required load then select the required rail length, (see part nos. L1017.25 through to L1017.65). Standard preload carriages are  $K_0$  (no preload) or  $K_1$  ( $0,02 \times$  dynamic load capacity). Other preloads available on request.

### Tips

**These are very heavy duty needle roller rail carriages and can only be used with corresponding needle roller rails L1017. For standard linear guideways and carriages see part no. L1016.**

Order No.	Rail size	$w_1$	$w_2$	$h_1$	$l_1$	$l_2$	$h_2$	$h_3$	$h_4$	$h_5$	$h_6$	$h_7$	$d_1$	Weight g
L1017.F35	35	100	34	48	122	84	42	13	31	17.0	5	16.4	M10	1700
L1017.F45	45	120	45	60	156	110	52	15	38	19.0	6	21.8	M12	3400

  

Order No.	$d_2$	$d_3$	$l_3$	$l_4$	$l_5$	$w_3$	$w_4$	$w_5$	Dyn. load $C_{rad \& ax}$ kN max.	Static load $C_{0rad \& ax}$ kN max.	Moment $M_x$ Nm max.	Moment $M_y$ Nm max.	Moment $M_z$ Nm max.
L1017.F35	9	14	62	19	40	33	82	41	57	154	2742	1946	1946
L1017.F45	14	20	80	29.2	52.5	37.5	100	50	95.9	255	6350	4450	4450



# Needle Roller - Unflanged Carriages

needle roller

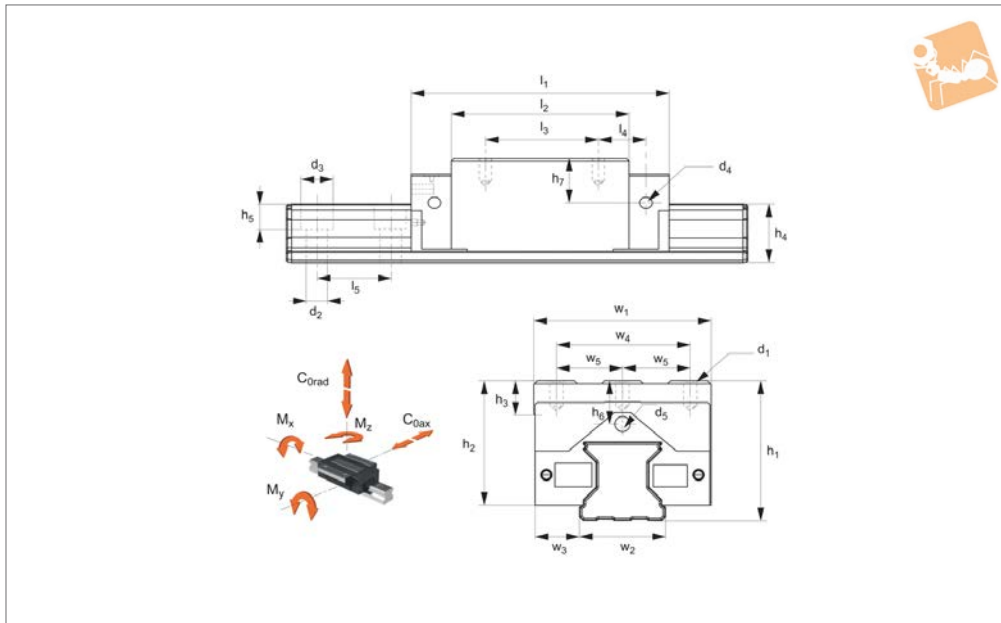

**L1017.U**

LINEAR GUIDEWAYS

**Material**

Hardened and ground steel.

**Technical Notes**

Needle roller linear guideways can take significantly higher loads than the same size standard (ball) linear guideways. Select the size and number of carriages to

suit the required load then select the required rail length, (see part nos. L1017.25 through to L1017.65). Standard preload carriages are  $K_0$  (no preload) or  $K_1$  (0,02 x dynamic load capacity). Other preloads available on request.

**Tips**

These are very heavy duty needle roller rail carriages and can only be used with corresponding needle roller rails L1017. For standard linear guideways and carriages see part no. L1016.

Order No.	Rail size	w <sub>1</sub>	w <sub>2</sub>	h <sub>1</sub>	l <sub>1</sub>	l <sub>2</sub>	h <sub>2</sub>	h <sub>3</sub>	h <sub>4</sub>	h <sub>5</sub>	h <sub>6</sub>	h <sub>7</sub>	d <sub>1</sub>	d <sub>2</sub>
L1017.U35	35	70	34	55	122	84	49	13	31	17.0	17	23.4	M8x16	9
L1017.U45	45	86	45	70	156	110	62	13	38	17.0	24.6	31.8	M10x20	14

Order No.	d <sub>3</sub>	d <sub>4</sub>	d <sub>5</sub>	l <sub>3</sub>	l <sub>4</sub>	l <sub>5</sub>	w <sub>3</sub>	w <sub>4</sub>	w <sub>5</sub>	Dyn. load C <sub>rad &amp; ax</sub> max. kN	Static load C <sub>0rad &amp; ax</sub> max. kN	Moment M <sub>x</sub> max. Nm	Moment M <sub>y</sub> max. Nm	Moment M <sub>z</sub> max. Nm
L1017.U35	14	M6x8	M6x12	50	25	40	18	50	25	57	154	2742	1946	1946
L1017.U45	20	M6x8	M6x12	60	39.2	52.5	20.5	60	30	95.9	255	6350	4450	4450



### L1017.25

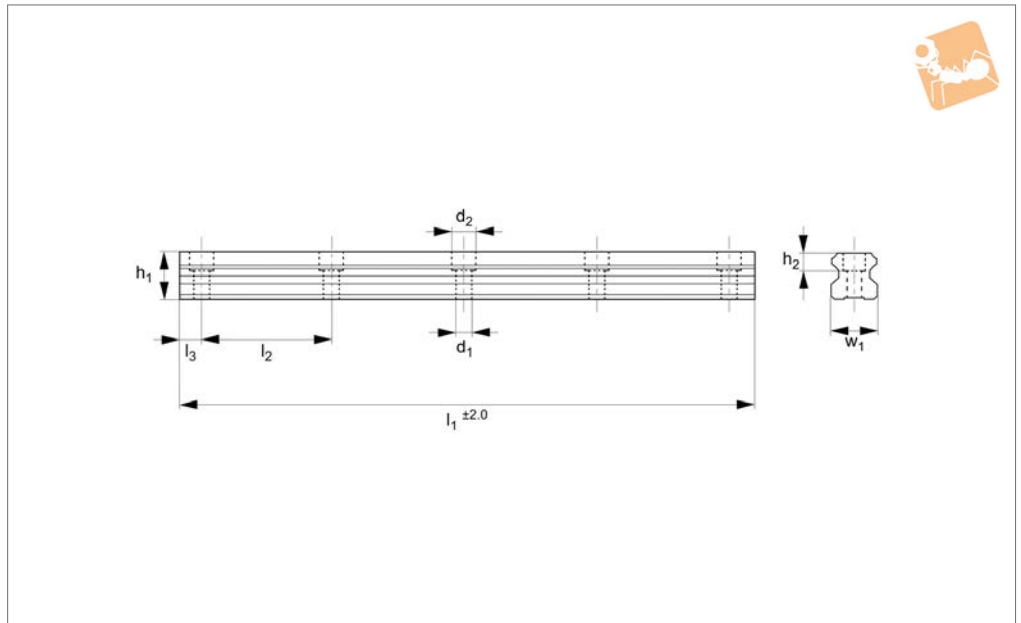

#### Material

Hardened and ground steel (typically 60 HRc).

#### Technical Notes

For carriages to suit the required load see

part nos. L1017.FN (flanged) and L1017.UN (unflanged).

Supplied with plastic covers for screws.

#### Tips

**These are very heavy duty needle roller**

**rails and can only be used with corresponding needle roller carriages L1017. For standard linear guideways and carriages see part no. L1016.**

Order No.	Rail size	w <sub>1</sub>	h <sub>1</sub>	l <sub>1</sub>	l <sub>2</sub>	For screws	h <sub>2</sub>	d <sub>1</sub>	d <sub>2</sub>	l <sub>3</sub>	Weight kg
L1017.25-0120	25	23	24.5	120	30	M6	9	7	11	14	0.41
L1017.25-0180	25	23	24.5	180	30	M6	9	7	11	14	0.61
L1017.25-0240	25	23	24.5	240	30	M6	9	7	11	14	0.82
L1017.25-0300	25	23	24.5	300	30	M6	9	7	11	14	1.02
L1017.25-0360	25	23	24.5	360	30	M6	9	7	11	14	1.22
L1017.25-0420	25	23	24.5	420	30	M6	9	7	11	14	1.43
L1017.25-0480	25	23	24.5	480	30	M6	9	7	11	14	1.63
L1017.25-0540	25	23	24.5	540	30	M6	9	7	11	14	1.84
L1017.25-0600	25	23	24.5	600	30	M6	9	7	11	14	2.04
L1017.25-0660	25	23	24.5	660	30	M6	9	7	11	14	2.24
L1017.25-0720	25	23	24.5	720	30	M6	9	7	11	14	2.45
L1017.25-0780	25	23	24.5	780	30	M6	9	7	11	14	2.65
L1017.25-0840	25	23	24.5	840	30	M6	9	7	11	14	2.86
L1017.25-0900	25	23	24.5	900	30	M6	9	7	11	14	3.06
L1017.25-0960	25	23	24.5	960	30	M6	9	7	11	14	3.26
L1017.25-1020	25	23	24.5	1020	30	M6	9	7	11	14	3.47
L1017.25-1080	25	23	24.5	1080	30	M6	9	7	11	14	3.67
L1017.25-1140	25	23	24.5	1140	30	M6	9	7	11	14	3.88
L1017.25-1200	25	23	24.5	1200	30	M6	9	7	11	14	4.08
L1017.25-1260	25	23	24.5	1260	30	M6	9	7	11	14	4.28
L1017.25-1320	25	23	24.5	1320	30	M6	9	7	11	14	4.49
L1017.25-1380	25	23	24.5	1380	30	M6	9	7	11	14	4.69
L1017.25-1440	25	23	24.5	1440	30	M6	9	7	11	14	4.90
L1017.25-1500	25	23	24.5	1500	30	M6	9	7	11	14	5.10
L1017.25-1560	25	23	24.5	1560	30	M6	9	7	11	14	5.30
L1017.25-1620	25	23	24.5	1620	30	M6	9	7	11	14	5.51
L1017.25-1680	25	23	24.5	1680	30	M6	9	7	11	14	5.71
L1017.25-1740	25	23	24.5	1740	30	M6	9	7	11	14	5.92
L1017.25-1800	25	23	24.5	1800	30	M6	9	7	11	14	6.12
L1017.25-1860	25	23	24.5	1860	30	M6	9	7	11	14	6.32
L1017.25-1920	25	23	24.5	1920	30	M6	9	7	11	14	6.53
L1017.25-1980	25	23	24.5	1980	30	M6	9	7	11	14	6.73



# 25mm Needle Roller Linear Rail

heavy duty



Linear Guide-ways

Order No.	Rail size	w <sub>1</sub>	h <sub>1</sub>	l <sub>1</sub>	l <sub>2</sub>	For screws	h <sub>2</sub>	d <sub>1</sub>	d <sub>2</sub>	l <sub>3</sub>	Weight kg
L1017.25-2040	25	23	24.5	2040	30	M6	9	7	11	14	6.94
L1017.25-2100	25	23	24.5	2100	30	M6	9	7	11	14	7.14
L1017.25-2160	25	23	24.5	2160	30	M6	9	7	11	14	7.34
L1017.25-2220	25	23	24.5	2220	30	M6	9	7	11	14	7.55
L1017.25-2280	25	23	24.5	2280	30	M6	9	7	11	14	7.75
L1017.25-2340	25	23	24.5	2340	30	M6	9	7	11	14	7.96
L1017.25-2400	25	23	24.5	2400	30	M6	9	7	11	14	8.16
L1017.25-2460	25	23	24.5	2460	30	M6	9	7	11	14	8.36
L1017.25-2520	25	23	24.5	2520	30	M6	9	7	11	14	8.57
L1017.25-2580	25	23	24.5	2580	30	M6	9	7	11	14	8.77
L1017.25-2640	25	23	24.5	2640	30	M6	9	7	11	14	8.98
L1017.25-2700	25	23	24.5	2700	30	M6	9	7	11	14	9.18
L1017.25-2760	25	23	24.5	2760	30	M6	9	7	11	14	9.38
L1017.25-2820	25	23	24.5	2820	30	M6	9	7	11	14	9.59
L1017.25-2880	25	23	24.5	2880	30	M6	9	7	11	14	9.79
L1017.25-2940	25	23	24.5	2940	30	M6	9	7	11	14	10.00
L1017.25-3000	25	23	24.5	3000	30	M6	9	7	11	14	10.20
L1017.25-3060	25	23	24.5	3060	30	M6	9	7	11	14	10.40
L1017.25-3120	25	23	24.5	3120	30	M6	9	7	11	14	10.61
L1017.25-3180	25	23	24.5	3180	30	M6	9	7	11	14	10.81
L1017.25-3240	25	23	24.5	3240	30	M6	9	7	11	14	11.02
L1017.25-3300	25	23	24.5	3300	30	M6	9	7	11	14	11.22
L1017.25-3360	25	23	24.5	3360	30	M6	9	7	11	14	11.42
L1017.25-3420	25	23	24.5	3420	30	M6	9	7	11	14	11.63
L1017.25-3480	25	23	24.5	3480	30	M6	9	7	11	14	11.83
L1017.25-3540	25	23	24.5	3540	30	M6	9	7	11	14	12.04
L1017.25-3600	25	23	24.5	3600	30	M6	9	7	11	14	12.24
L1017.25-3660	25	23	24.5	3660	30	M6	9	7	11	14	12.44
L1017.25-3720	25	23	24.5	3720	30	M6	9	7	11	14	12.65
L1017.25-3780	25	23	24.5	3780	30	M6	9	7	11	14	12.85
L1017.25-3840	25	23	24.5	3840	30	M6	9	7	11	14	13.06
L1017.25-3900	25	23	24.5	3900	30	M6	9	7	11	14	13.26
L1017.25-3960	25	23	24.5	3960	30	M6	9	7	11	14	13.46

LINEAR GUIDEWAYS

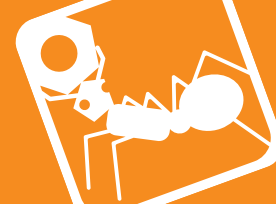

## L1017.35

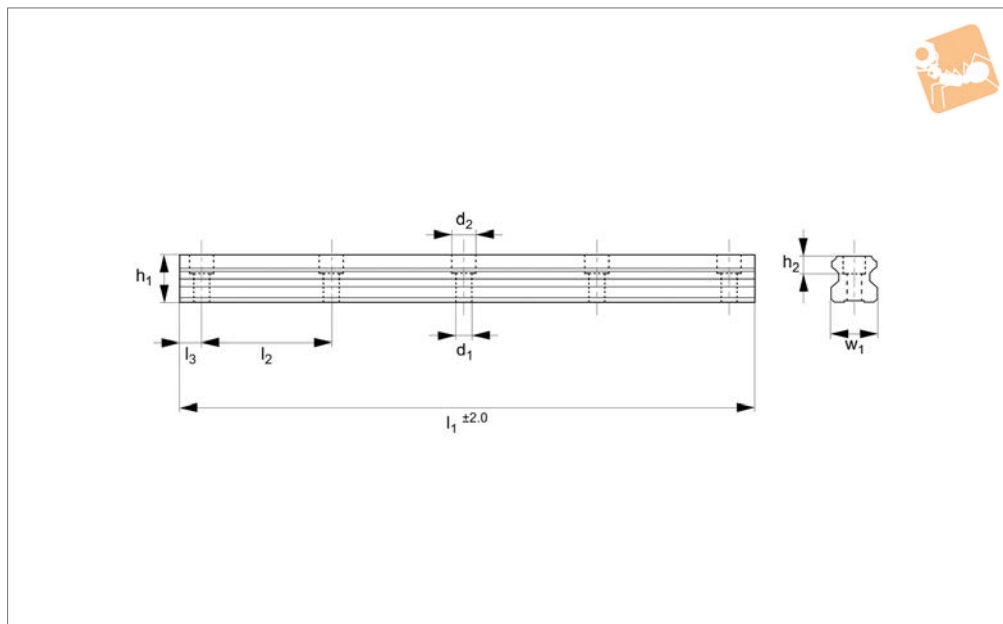

### Material

Hardened and ground steel (typically 60 HRC).

### Technical Notes

For carriages to suit the required load see

part nos. L1017.FN (flanged) and L1017.UN (unflanged).  
Supplied with plastic covers for screws.

### Tips

**These are very heavy duty needle roller**

**rails and can only be used with corresponding needle roller carriages L1017. For standard linear guideways and carriages see part no. L1016.**

Order No.	Rail size	w <sub>1</sub>	h <sub>1</sub>	l <sub>1</sub>	l <sub>2</sub>	For screws	h <sub>2</sub>	d <sub>1</sub>	d <sub>2</sub>	l <sub>3</sub>	Weight kg
L1017.35-0320	30	34	32	320	40	M8	17	9	15	20	18.4
L1017.35-0400	30	34	32	400	40	M8	17	9	15	20	23.0
L1017.35-0480	30	34	32	480	40	M8	17	9	15	20	27.6
L1017.35-0560	30	34	32	560	40	M8	17	9	15	20	32.1
L1017.35-0640	30	34	32	640	40	M8	17	9	15	20	36.7
L1017.35-0720	30	34	32	720	40	M8	17	9	15	20	41.3
L1017.35-0800	30	34	32	800	40	M8	17	9	15	20	45.9
L1017.35-0880	30	34	32	880	40	M8	17	9	15	20	50.5
L1017.35-0960	30	34	32	960	40	M8	17	9	15	20	55.1
L1017.35-1040	30	34	32	1040	40	M8	17	9	15	20	2.3
L1017.35-1120	30	34	32	1120	40	M8	17	9	15	20	6.9
L1017.35-1200	30	34	32	1200	40	M8	17	9	15	20	11.5
L1017.35-1280	30	34	32	1280	40	M8	17	9	15	20	16.1
L1017.35-1360	30	34	32	1360	40	M8	17	9	15	20	20.7
L1017.35-1440	30	34	32	1440	40	M8	17	9	15	20	25.3
L1017.35-1520	30	34	32	1520	40	M8	17	9	15	20	29.8
L1017.35-1600	30	34	32	1600	40	M8	17	9	15	20	34.4
L1017.35-1680	30	34	32	1680	40	M8	17	9	15	20	39.0
L1017.35-1760	30	34	32	1760	40	M8	17	9	15	20	43.6
L1017.35-1840	30	34	32	1840	40	M8	17	9	15	20	48.2
L1017.35-1920	30	34	32	1920	40	M8	17	9	15	20	52.8
L1017.35-2000	30	34	32	2000	40	M8	17	9	15	20	0.0
L1017.35-2080	30	34	32	2080	40	M8	17	9	15	20	4.6
L1017.35-2160	30	34	32	2160	40	M8	17	9	15	20	9.2
L1017.35-2240	30	34	32	2240	40	M8	17	9	15	20	13.8
L1017.35-2320	30	34	32	2320	40	M8	17	9	15	20	18.4
L1017.35-2400	30	34	32	2400	40	M8	17	9	15	20	23.0
L1017.35-2480	30	34	32	2480	40	M8	17	9	15	20	27.6
L1017.35-2560	30	34	32	2560	40	M8	17	9	15	20	32.1
L1017.35-2640	30	34	32	2640	40	M8	17	9	15	20	36.7
L1017.35-2720	30	34	32	2720	40	M8	17	9	15	20	41.3
L1017.35-2800	30	34	32	2800	40	M8	17	9	15	20	45.9



# 35mm Needle Roller Linear Rail

heavy duty



Order No.	Rail size	w <sub>1</sub>	h <sub>1</sub>	l <sub>1</sub>	l <sub>2</sub>	For screws	h <sub>2</sub>	d <sub>1</sub>	d <sub>2</sub>	l <sub>3</sub>	Weight kg
L1017.35-2880	30	34	32	2880	40	M8	17	9	15	20	50.5
L1017.35-2960	30	34	32	2960	40	M8	17	9	15	20	55.1
L1017.35-3040	30	34	32	3040	40	M8	17	9	15	20	2.3
L1017.35-3120	30	34	32	3120	40	M8	17	9	15	20	6.9
L1017.35-3200	30	34	32	3200	40	M8	17	9	15	20	11.5
L1017.35-3280	30	34	32	3280	40	M8	17	9	15	20	16.1
L1017.35-3360	30	34	32	3360	40	M8	17	9	15	20	20.7
L1017.35-3440	30	34	32	3440	40	M8	17	9	15	20	25.3
L1017.35-3520	30	34	32	3520	40	M8	17	9	15	20	29.8
L1017.35-3600	30	34	32	3600	40	M8	17	9	15	20	34.4
L1017.35-3680	30	34	32	3680	40	M8	17	9	15	20	39.0
L1017.35-3760	30	34	32	3760	40	M8	17	9	15	20	43.6
L1017.35-3840	30	34	32	3840	40	M8	17	9	15	20	48.2
L1017.35-3920	30	34	32	3920	40	M8	17	9	15	20	52.8
L1017.35-4000	30	34	32	4000	40	M8	17	9	15	20	229.6

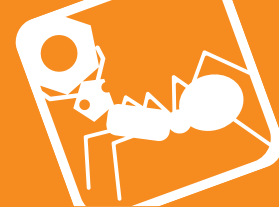

## L1017.45

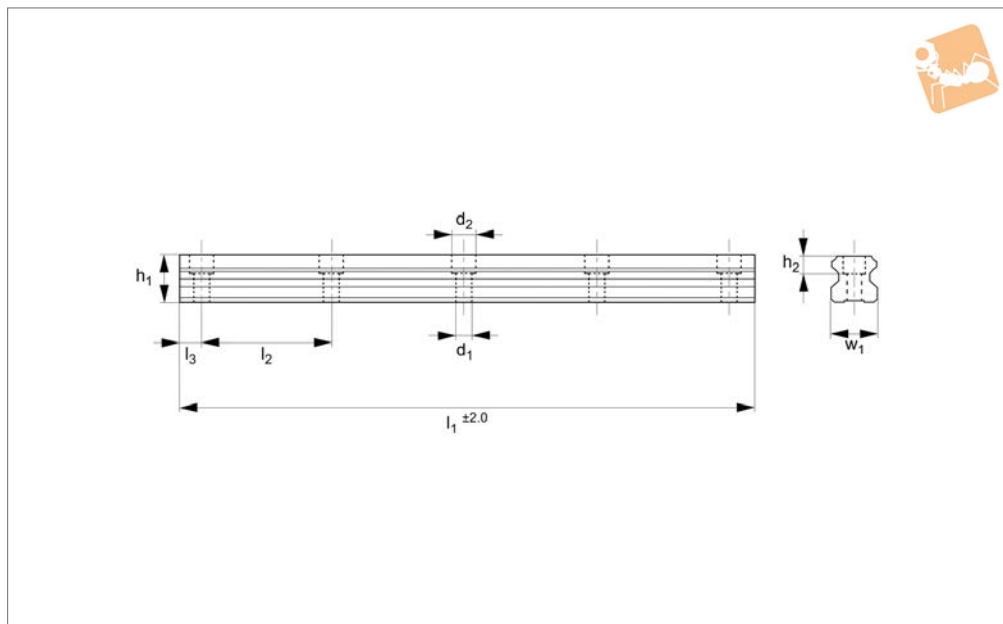

### Material

Hardened and ground steel (typically 60 HRc).

### Technical Notes

For carriages to suit the required load see

part nos. L1017.FN (flanged) and L1017.UN (unflanged).

Supplied with plastic covers for screws.

### Tips

**These are very heavy duty needle roller**

**rails and can only be used with corresponding needle roller carriages L1017. For standard linear guideways and carriages see part no. L1016.**

Order No.	Rail size	w <sub>1</sub>	h <sub>1</sub>	l <sub>1</sub>	l <sub>2</sub>	For screw	h <sub>2</sub>	d <sub>1</sub>	d <sub>2</sub>	l <sub>3</sub>	Weight kg
L1017.45-0320	45	45	40	320	52.5	M12	17	14	20	25	3.42
L1017.45-0400	45	45	40	400	52.5	M12	17	14	20	25	4.28
L1017.45-0480	45	45	40	480	52.5	M12	17	14	20	25	5.14
L1017.45-0560	45	45	40	560	52.5	M12	17	14	20	25	5.99
L1017.45-0640	45	45	40	640	52.5	M12	17	14	20	25	6.85
L1017.45-0720	45	45	40	720	52.5	M12	17	14	20	25	7.70
L1017.45-0800	45	45	40	800	52.5	M12	17	14	20	25	8.56
L1017.45-0880	45	45	40	880	52.5	M12	17	14	20	25	9.42
L1017.45-0960	45	45	40	960	52.5	M12	17	14	20	25	10.27
L1017.45-1040	45	45	40	1040	52.5	M12	17	14	20	25	11.13
L1017.45-1120	45	45	40	1120	52.5	M12	17	14	20	25	11.98
L1017.45-1200	45	45	40	1200	52.5	M12	17	14	20	25	12.84
L1017.45-1280	45	45	40	1280	52.5	M12	17	14	20	25	13.70
L1017.45-1360	45	45	40	1360	52.5	M12	17	14	20	25	14.55
L1017.45-1440	45	45	40	1440	52.5	M12	17	14	20	25	15.41
L1017.45-1520	45	45	40	1520	52.5	M12	17	14	20	25	16.26
L1017.45-1600	45	45	40	1600	52.5	M12	17	14	20	25	17.12
L1017.45-1680	45	45	40	1680	52.5	M12	17	14	20	25	17.98
L1017.45-1760	45	45	40	1760	52.5	M12	17	14	20	25	18.83
L1017.45-1840	45	45	40	1840	52.5	M12	17	14	20	25	19.69
L1017.45-1920	45	45	40	1920	52.5	M12	17	14	20	25	20.54
L1017.45-2000	45	45	40	2000	52.5	M12	17	14	20	25	21.40
L1017.45-2080	45	45	40	2080	52.5	M12	17	14	20	25	22.26
L1017.45-2160	45	45	40	2160	52.5	M12	17	14	20	25	23.11
L1017.45-2240	45	45	40	2240	52.5	M12	17	14	20	25	23.97
L1017.45-2320	45	45	40	2320	52.5	M12	17	14	20	25	24.82
L1017.45-2400	45	45	40	2400	52.5	M12	17	14	20	25	25.68
L1017.45-2480	45	45	40	2480	52.5	M12	17	14	20	25	26.54
L1017.45-2560	45	45	40	2560	52.5	M12	17	14	20	25	27.39
L1017.45-2640	45	45	40	2640	52.5	M12	17	14	20	25	28.25
L1017.45-2720	45	45	40	2720	52.5	M12	17	14	20	25	29.10
L1017.45-2800	45	45	40	2800	52.5	M12	17	14	20	25	29.96





# 45mm Needle Roller Linear Rail

heavy duty

Linear Guide-  
ways

Order No.	Rail size	w <sub>1</sub>	h <sub>1</sub>	l <sub>1</sub>	l <sub>2</sub>	For screw	h <sub>2</sub>	d <sub>1</sub>	d <sub>2</sub>	l <sub>3</sub>	Weight kg
L1017.45-2880	45	45	40	2880	52.5	M12	17	14	20	25	30.82
L1017.45-2960	45	45	40	2960	52.5	M12	17	14	20	25	31.67
L1017.45-3040	45	45	40	3040	52.5	M12	17	14	20	25	32.53
L1017.45-3120	45	45	40	3120	52.5	M12	17	14	20	25	33.38
L1017.45-3200	45	45	40	3200	52.5	M12	17	14	20	25	34.24
L1017.45-3280	45	45	40	3280	52.5	M12	17	14	20	25	35.10
L1017.45-3360	45	45	40	3360	52.5	M12	17	14	20	25	35.95
L1017.45-3440	45	45	40	3440	52.5	M12	17	14	20	25	36.81
L1017.45-3520	45	45	40	3520	52.5	M12	17	14	20	25	37.66
L1017.45-3600	45	45	40	3600	52.5	M12	17	14	20	25	38.52
L1017.45-3680	45	45	40	3680	52.5	M12	17	14	20	25	39.38
L1017.45-3760	45	45	40	3760	52.5	M12	17	14	20	25	40.23
L1017.45-3840	45	45	40	3840	52.5	M12	17	14	20	25	41.09
L1017.45-3920	45	45	40	3920	52.5	M12	17	14	20	25	41.94
L1017.45-4000	45	45	40	4000	52.5	M12	17	14	20	25	42.80

LINEAR GUIDEWAYS

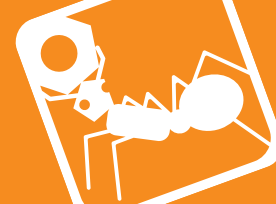

## L1017.55

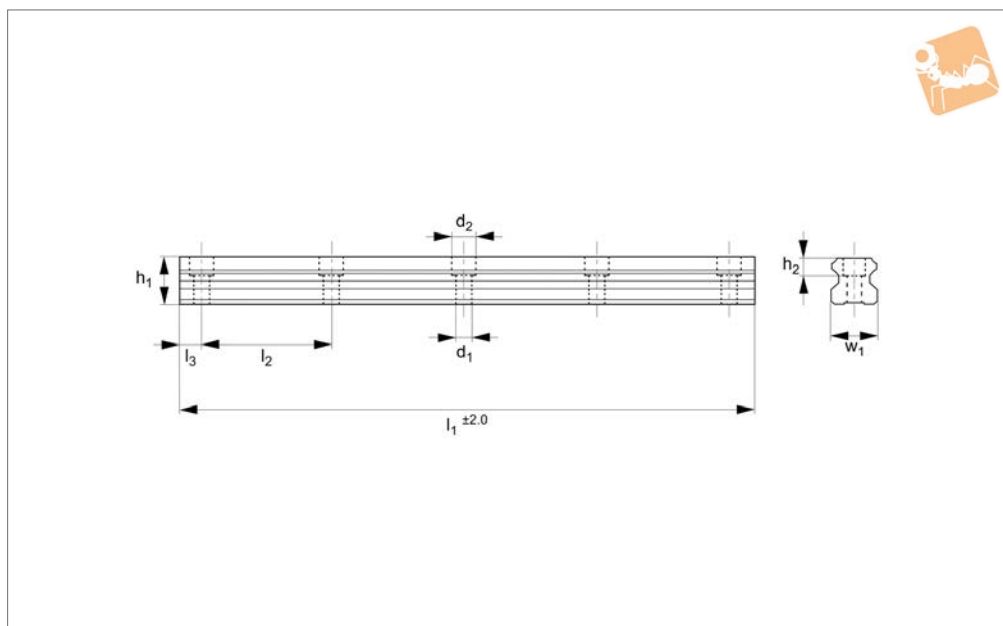

### Material

Hardened and ground steel (typically 60 HRc).

### Technical Notes

For carriages to suit the required load see

part nos. L1017.FN (flanged) and L1017.UN (unflanged).

Supplied with plastic covers for screws.

### Tips

These are very heavy duty needle roller

rails and can only be used with corresponding needle roller carriages L1017. For standard linear guideways and carriages see part no. L1016.

Order No.	Rail size	w <sub>1</sub>	h <sub>1</sub>	l <sub>1</sub>	l <sub>2</sub>	For screws	h <sub>2</sub>	d <sub>1</sub>	d <sub>2</sub>	l <sub>3</sub>	Weight kg
L1017.55-0315	55	53	48	315	60	M14	20	16	24	29	4.79
L1017.55-0420	55	53	48	420	60	M14	20	16	24	29	6.38
L1017.55-0525	55	53	48	525	60	M14	20	16	24	29	7.98
L1017.55-0630	55	53	48	630	60	M14	20	16	24	29	9.58
L1017.55-0735	55	53	48	735	60	M14	20	16	24	29	11.17
L1017.55-0840	55	53	48	840	60	M14	20	16	24	29	12.77
L1017.55-0945	55	53	48	945	60	M14	20	16	24	29	14.36
L1017.55-0960	55	53	48	960	60	M14	20	16	24	29	14.59
L1017.55-1050	55	53	48	1050	60	M14	20	16	24	29	15.96
L1017.55-1155	55	53	48	1155	60	M14	20	16	24	29	17.56
L1017.55-1260	55	53	48	1260	60	M14	20	16	24	29	19.15
L1017.55-1365	55	53	48	1365	60	M14	20	16	24	29	20.75
L1017.55-1470	55	53	48	1470	60	M14	20	16	24	29	22.34
L1017.55-1575	55	53	48	1575	60	M14	20	16	24	29	23.94
L1017.55-1680	55	53	48	1680	60	M14	20	16	24	29	25.54
L1017.55-1785	55	53	48	1785	60	M14	20	16	24	29	27.13
L1017.55-1890	55	53	48	1890	60	M14	20	16	24	29	28.73
L1017.55-1995	55	53	48	1995	60	M14	20	16	24	29	30.32
L1017.55-2100	55	53	48	2100	60	M14	20	16	24	29	31.92
L1017.55-2205	55	53	48	2205	60	M14	20	16	24	29	33.52
L1017.55-2310	55	53	48	2310	60	M14	20	16	24	29	35.11
L1017.55-2415	55	53	48	2415	60	M14	20	16	24	29	36.71
L1017.55-2520	55	53	48	2520	60	M14	20	16	24	29	38.30
L1017.55-2625	55	53	48	2625	60	M14	20	16	24	29	39.90
L1017.55-2730	55	53	48	2730	60	M14	20	16	24	29	41.50
L1017.55-2835	55	53	48	2835	60	M14	20	16	24	29	43.09
L1017.55-2940	55	53	48	2940	60	M14	20	16	24	29	44.69
L1017.55-3045	55	53	48	3045	60	M14	20	16	24	29	46.28
L1017.55-3150	55	53	48	3150	60	M14	20	16	24	29	47.88
L1017.55-3255	55	53	48	3255	60	M14	20	16	24	29	49.48
L1017.55-3360	55	53	48	3360	60	M14	20	16	24	29	51.07
L1017.55-3465	55	53	48	3465	60	M14	20	16	24	29	52.67



# 55mm Needle Roller Linear Rail

heavy duty

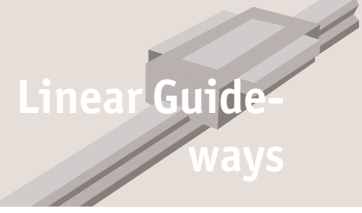

Linear Guide-ways

Order No.	Rail size	w <sub>1</sub>	h <sub>1</sub>	l <sub>1</sub>	l <sub>2</sub>	For screws	h <sub>2</sub>	d <sub>1</sub>	d <sub>2</sub>	l <sub>3</sub>	Weight kg
L1017.55-3570	55	53	48	3570	60	M14	20	16	24	29	54.26
L1017.55-3675	55	53	48	3675	60	M14	20	16	24	29	55.86
L1017.55-3780	55	53	48	3780	60	M14	20	16	24	29	57.46
L1017.55-3885	55	53	48	3885	60	M14	20	16	24	29	59.05
L1017.55-3990	55	53	48	3990	60	M14	20	16	24	29	60.65



- Carriage types

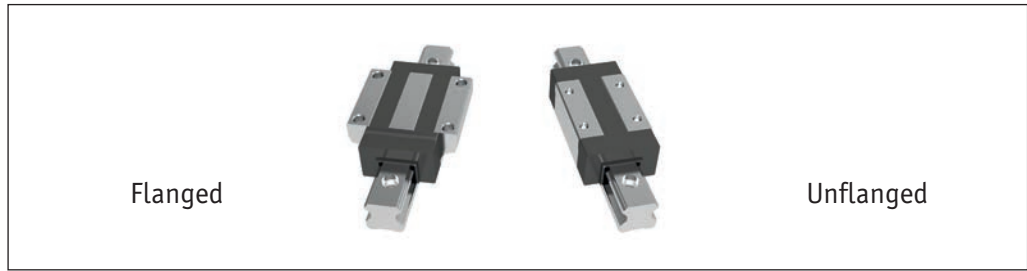

Carriage lengths

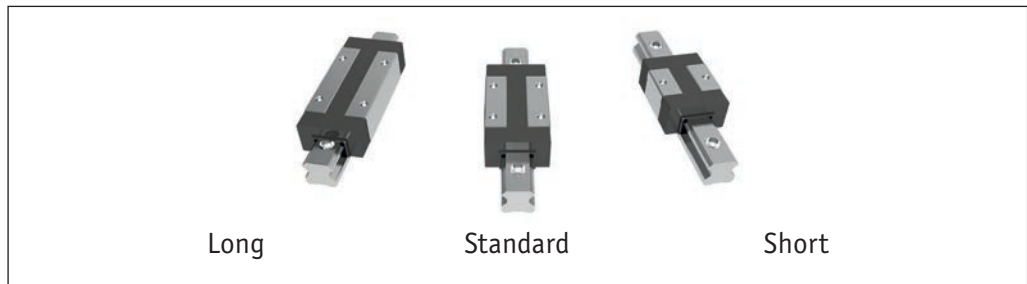

Rail types

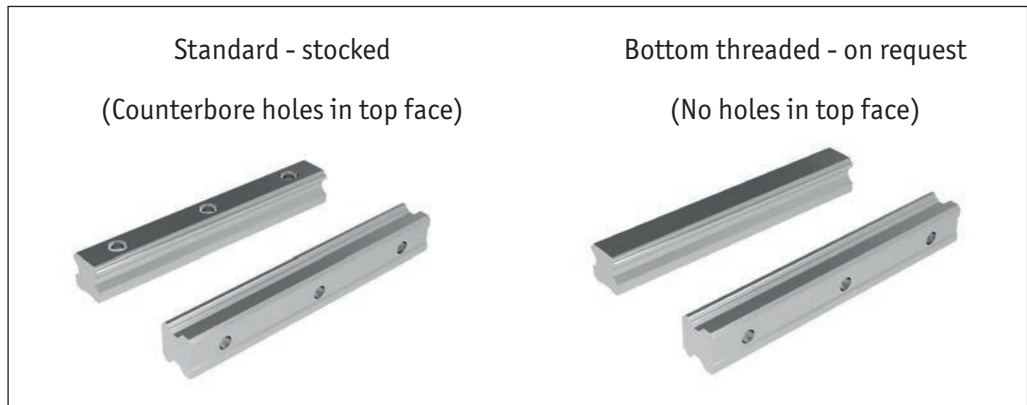

Linear Guideways from Automation Components

### CAD - Download in 3 easy steps

Most of our products are available to download directly from our website. Get the CAD you need for your application in minutes, no registration required.

<p><b>Step 1: find the part you need</b></p> <p>Find the part or enter the Automation part number into the search bar.</p>	
<p><b>Step 2: Choose the CAD option</b></p> <p>Click on the CAD button below the product window to the right of the drawing.</p>	
<p><b>Step 3: Download your format</b></p> <p>Choose the the format you require, and download it to your computer.</p>	

### Load capacities – explained

- A number of load figures are stated for load capacity:

**Dynamic Load** – this is the main figure considered for linear guideways. It is the moving load that the system can bear. It takes account of the total moving load as well as considerations such as impact, vibration and fatigue.

**Static Load** – this is a load that is constant for an extended time (i.e. the dead load the system can bear before any movement). It can be in tension or compression.

For these linear guideways the radial and axial load capacities are the same.

Moment loads are twisting loads generated by offset loads in either X, Y or Z planes. Moment loads can be reduced by adding further carriages or rails to reduce any twisting of the carriage due to the load offset.

### Straightness of rails

- The measurements of the straightness of the system are taken from the running accuracy of the sliders over the length of the rails (given in microns) – see system precision page.
- For standard accuracy this equates to around 20 microns for a metre length, increasing to 35 microns for a 4 metre length.

### What lengths can be provided?

- We have standard rail lengths. These are based on the hole pitch of the rails and end machining to provide an equidistant length to the first and last hole centre.
- However we can cut the rail (from stock) to any length required – we just need to know the distance required to the first hole.
- In general our cutting procedures allow for a  $\pm 2$ mm accuracy on the overall rail length. If greater accuracy than this is required then we have to machine the end accurately (rather than cut it) and this involves extra time and cost.
- Standard maximum length for each rail size is around 4 metres. Rails can be joined together but the preparation needs to be made in our workshop. The rails will be marked clearly with the ends to be placed adjacent to each other.

### Installation

- The linear guideways are very accurate and as a result need to be installed on accurately prepared surfaces – please see installation instructions. If the two rails are installed parallel to each other, they need to be accurately aligned – see assembly precision page.
- If you are not able to prepare the surface as accurately as required you might want to consider using our Compact Rail system, as this has a master rail (T rail) and a slave rail (U rail) that allows for structural inaccuracies.

### Mounting the carriages to the rails

- In general the carriages will be supplied separately to the rails. To install the carriage onto the rails, offer the carriage up to the rails and slide it onto the rail itself.

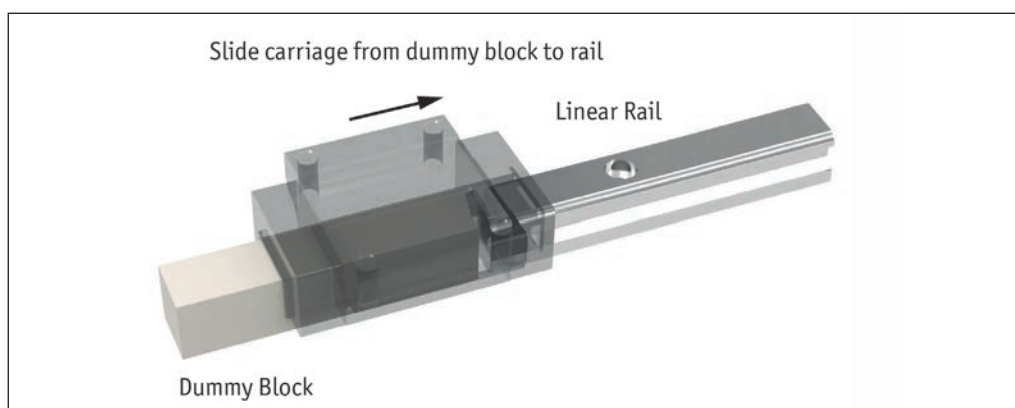

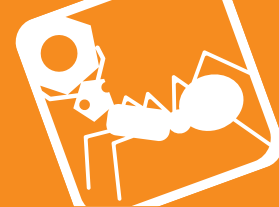

**New ball chain technology**

Our new and improved linear guideway systems include the latest “ball chain” technology with the following benefits:

- Higher maximum velocity.
- Lower heat generation
- Lower noise generation.
- Very smooth running.
- Optimised lubrication system
- Even load distribution
- Longer service life

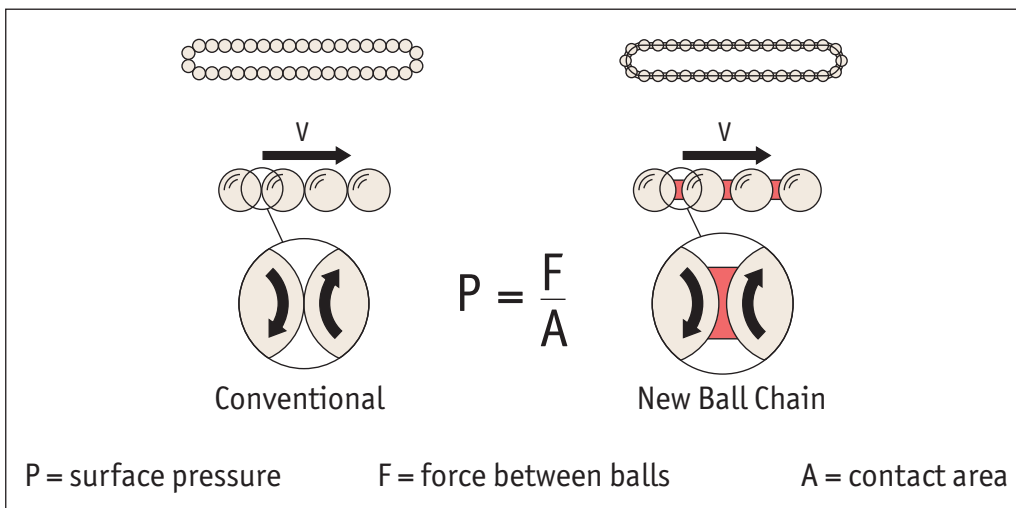

The rotating balls in conventional profile rail guides have point contact between each other. The rotation speed at the contact point is double the speed of the balls. The contact area (A) is so small that the surface pressure (P) tends towards infinity. This leads to heating and wear of the balls and the linear guide system.

The chain system in our new linear guides have a relatively large contact area (A), this significantly reduces the surface area pressure (P). The rotation speeds at the contact surfaces of ball and chain are the same. The ball chain is used to transport the lubricant and to create a lubrication film on the balls. The design of the carriage allows effective supply of lubricant from the lubricant connection to the circulation areas of the ball chains.

This design of the of the ball chain ends in connection with the spacer ball closes the circulation and makes the movement of the carriage smooth and quiet.

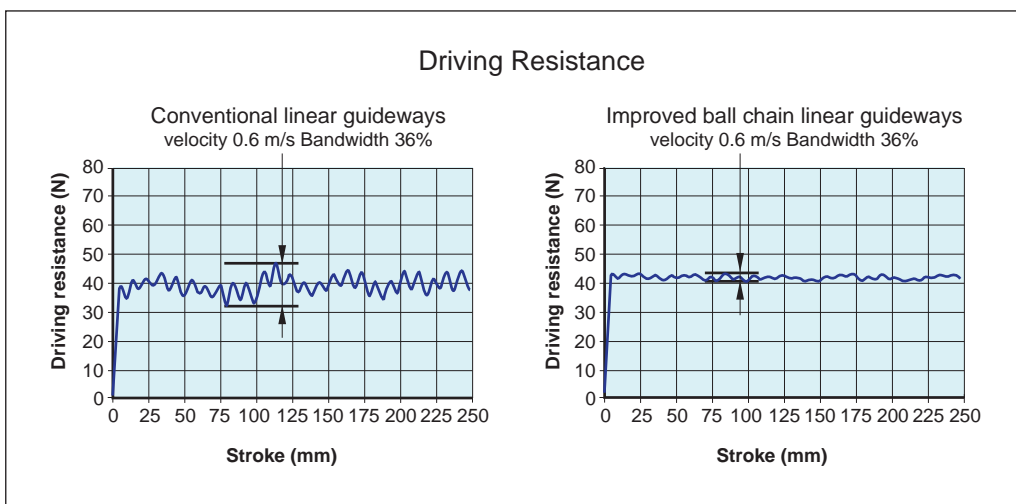

Linear Guideways from Automation Components

LINEAR GUIDEWAYS

#### New technology

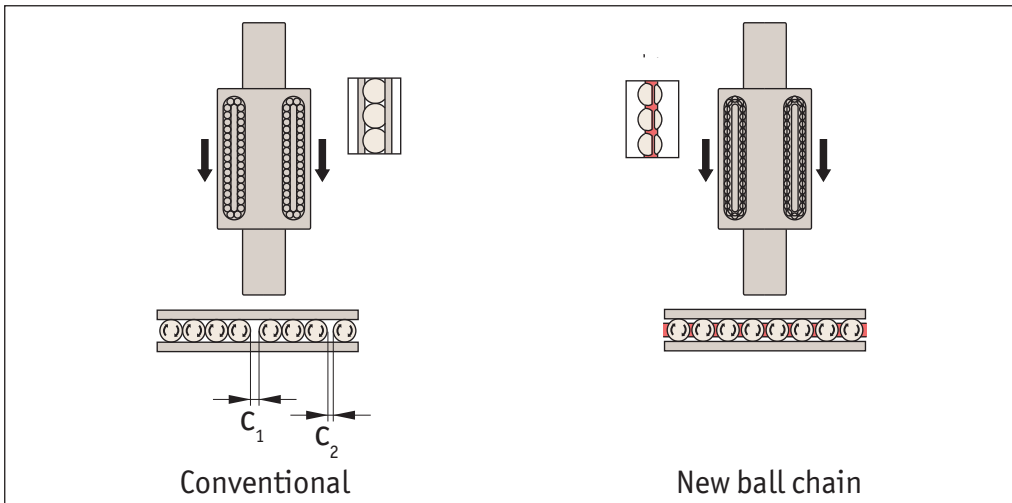

It is not possible to keep the distance of the balls ( $C_1$ ,  $C_2$ ) constant in conventional linear guides. These irregular distances between the balls lead to uneven running behaviour.

The new ball chain system also allows the balls to be continuously supplied with lubricant, which reduces wear of the metal. This significantly extends the service life of the system and reduces lubricant and the maintenance intervals.

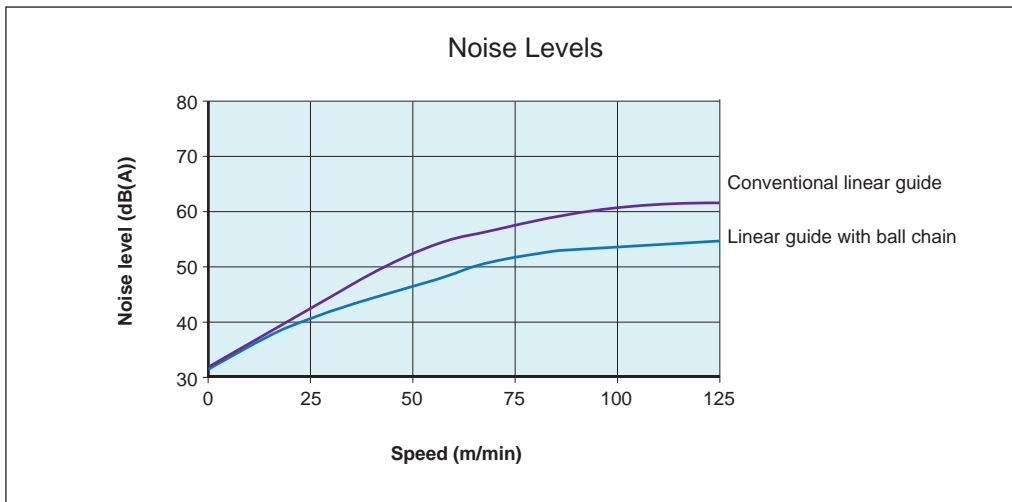

We can coat our rail with two types of corrosion protective finishes:

- Raydent coating; this is an electro-chemical process that applies a black oxide-ceramic layer (approx. 1 micron thick) that penetrates into the metal. As coating takes place at 0C the parts are not deformed. Good resistance against acids, bases and solvents.
- Chemical nickel coating; this offers a good resistance to corrosion, abrasion and chemicals. Black finish.

Please ask our technical department to help you select the best coating.

All of our rails are issued with oil-resistant plastic caps used to cover the screw holes. If there are aggressive chemicals present we can also provide brass versions of these caps.

Where there may be a high level of dust, dirt, weld splatters etc. we can provide bellows covers to protect the rails.



Load capacity overview - L1016.F Flanged carriages

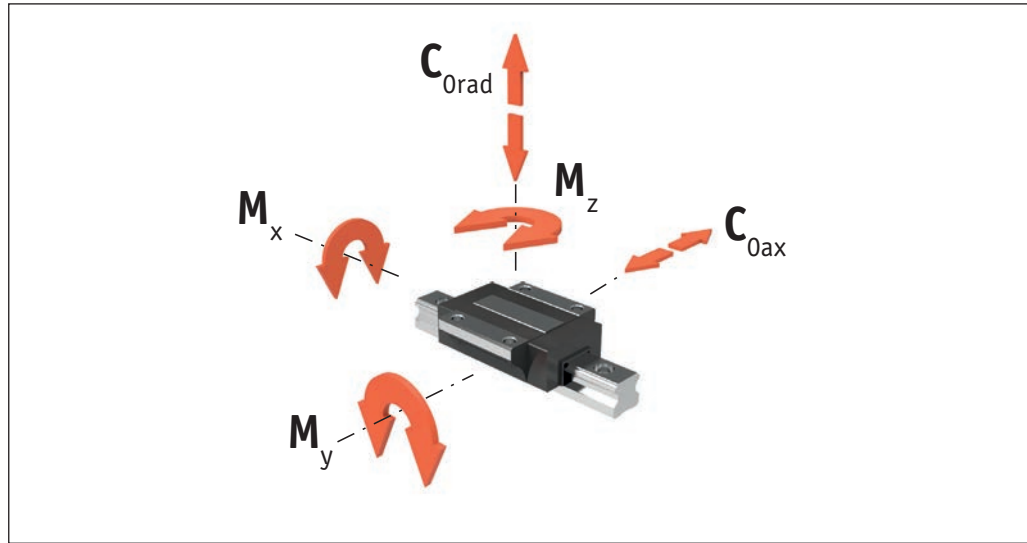

Linear Guideways from Automation Components

Part no.	Type	Length	Max. load capacities kN		Max. static moments Nm		
			Dynamic Load C <sub>kN</sub>	Static load C <sub>Orad+ax</sub> kN	M <sub>x</sub> Nm	M <sub>y</sub> Nm	M <sub>z</sub> Nm
L1016.F15	Flanged	Standard	11,67	19,90	137	120	120
L1016.F15-L	Flanged	Long	14,12	24,05	166	171	171
L1016.F20	Flanged	Standard	17,98	30,96	289	224	224
L1016.F20-L	Flanged	Long	23,30	40,11	376	366	366
L1016.F25	Flanged	Standard	25,25	41,73	447	358	358
L1016.F25-L	Flanged	Long	32,44	53,63	576	577	577
L1016.F25-XL	Flanged	Extra Long	36,58	64,30	691	833	833
L1016.F30	Flanged	Standard	37,33	55,50	719	560	560
L1016.F30-L	Flanged	Long	48,35	71,88	931	836	836
L1016.F30-XL	Flanged	Extra Long	53,83	88,18	1142	1361	1361
L1016.F35	Flanged	Standard	53,31	82,66	1307	991	991
L1016.F35-L	Flanged	Long	66,61	103,29	1633	1424	1424
L1016.F35-XL	Flanged	Extra Long	73,29	127,68	2020	2330	2330
L1016.F45	Flanged	Standard	73,14	111,30	2353	1559	1559
L1016.F45-L	Flanged	Long	86,99	132,39	2798	2170	2170
L1016.F45-XL	Flanged	Extra Long	100,52	166,87	3527	3455	3455
L1016.F55	Flanged	Standard	88,26	136,62	3385	2361	2361
L1016.F55-L	Flanged	Long	119,10	183,14	4538	4202	4202
L1016.F55-XL	Flanged	Extra Long	161,43	259,71	6430	6617	6617



### Load capacity overview - L1016.U Unflanged carriages

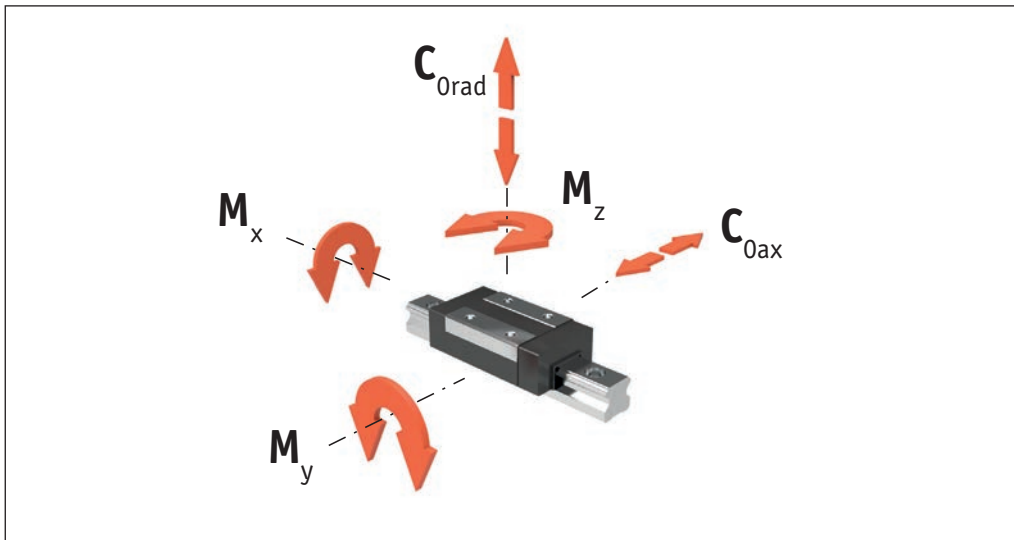

Part no.	Type	Length	Max. load capacities kN		Max. static moments Nm		
			dyn. $C_{rad}$ dyn. $C_{ax}$	stat. $C_{Orad}$ stat. $C_{Oax}$	$M_x$	$M_y$	$M_z$
L1016.U15	Unflanged	Standard	11,67	19,90	137	120	120
L1016.U20	Unflanged	Standard	17,98	30,96	289	224	224
L1016.U20-L	Unflanged	Long	23,30	40,11	376	366	366
L1016.U25	Unflanged	Standard	25,25	41,73	447	358	358
L1016.U25-L	Unflanged	Long	32,44	53,63	576	577	577
L1016.U25-XL	Unflanged	Extra Long	36,58	64,30	691	833	833
L1016.U30	Unflanged	Standard	37,33	55,50	719	560	560
L1016.U30-L	Unflanged	Long	48,35	71,88	931	836	836
L1016.U30-XL	Unflanged	Extra Long	53,83	88,18	1142	1361	1361
L1016.U35	Unflanged	Standard	53,31	82,66	1307	991	991
L1016.U35-L	Unflanged	Long	66,61	103,29	1633	1424	1424
L1016.U35-XL	Unflanged	Extra Long	73,29	127,68	2020	2330	2330
L1016.U45	Unflanged	Standard	73,14	111,30	2353	1559	1559
L1016.U45-L	Unflanged	Long	86,99	132,39	2798	2170	2170
L1016.U45-XL	Unflanged	Extra Long	100,52	166,87	3527	3455	3455
L1016.U55	Unflanged	Standard	88,26	136,62	3385	2361	2361
L1016.U55-L	Unflanged	Long	119,10	183,14	4538	4202	4202
L1016.U55-XL	Unflanged	Extra Long	161,43	259,71	6430	6617	6617

Linear Guideways from Automation Components

LINEAR GUIDEWAYS



Load capacity overview - L1016.UL Unflanged low height carriages

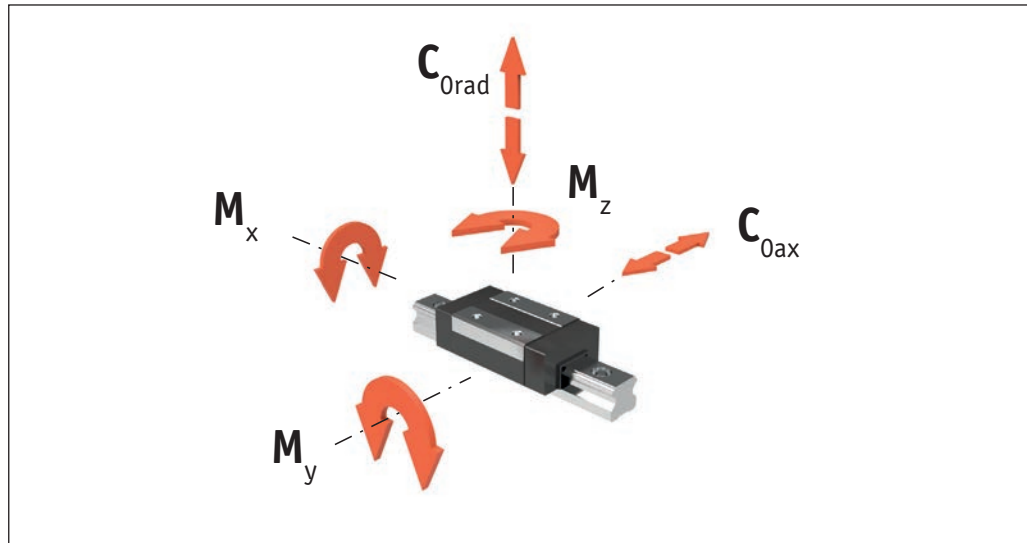

Linear Guideways from Automation Components

Part no.	Type	Length	Max. load capacities kN		Max. static moments Nm		
			dyn. $C_{rad}$ dyn. $C_{ax}$	stat. $C_{Orad}$ stat. $C_{Oax}$	$M_x$	$M_y$	$M_z$
L1016.UL15-S	Unflanged	Short	5,81	9,90	69	32	32
L1016.UL15	Unflanged	Standard	11,67	19,90	137	120	120
L1016.UL15-L	Unflanged	Long	14,12	24,05	166	171	171
L1016.UL20-S	Unflanged	Short	9,25	15,63	148	66	66
L1016.UL20	Unflanged	Standard	17,98	30,96	289	224	224
L1016.UL25-S	Unflanged	Short	12,87	21,34	230	103	103
L1016.UL25	Unflanged	Standard	25,25	41,73	447	358	358
L1016.UL30-S	Unflanged	Short	18,50	27,51	356	153	153
L1016.UL30	Unflanged	Standard	37,33	55,50	719	560	560
L1016.UL30-L	Unflanged	Long	48,35	71,88	931	836	836
L1016.UL30-XL	Unflanged	Extra Long	53,83	88,18	1142	1361	1361
L1016.UL35-S	Unflanged	Short	26,72	41,43	655	275	275
L1016.UL35	Unflanged	Standard	53,31	82,66	1307	991	991
L1016.UL35-L	Unflanged	Long	66,61	103,29	1633	1424	1424
L1016.UL35-XL	Unflanged	Extra Long	73,29	127,68	2020	2330	2330
L1016.UL45	Unflanged	Standard	73,14	111,30	2353	1559	1559
L1016.UL45-L	Unflanged	Long	86,99	132,39	2798	2170	2170
L1016.UL45-XL	Unflanged	Extra Long	100,52	166,87	3527	3455	3455
L1016.UL55	Unflanged	Standard	88,26	136,62	3385	2361	2361
L1016.UL55-L	Unflanged	Long	119,10	183,14	4538	4202	4202
L1016.UL55-XL	Unflanged	Extra Long	161,43	259,71	6430	6617	6617

#### Manual rail clamps

- Many of our customers wish to lock their moving element in position on the rails. Whilst this can be relatively simply achieved with the use of an adjustable clamping handle and thrust pad, we also offer a clamping element which can be integrated into your rail/system design.
- This is available in the standard manual version as well as (on request) a pneumatic version for linear guideways only (not compact rail systems).
- These manual clamps have a holding force of up to 2,000N.
- They are relatively compact in shape. Please bear in mind the extra space required for the clamping element when calculating the total stroke you require.

#### Applications

- Table cross beams.
- Sliding beds.
- Width adjustment stops.
- Positioning of optical equipment.



The manual rail clamps are used alongside the standard flanged or unflanged rail carriages.

When selecting ensure:

- a) the rail clamp suits the rail that you are using.
- b) that the total assembly height of the rail clamp is the same as that of the rail carriage L1016.U or L1016.F.



**Radial clearance/preload**

Radial clearance describes the value for the radial movement of the carriage at a constant vertical load, while the carriage moves in longitudinal direction.

Preload is defined as an effective load on the rolling element in the interior of the carriage in order to remove an existing clearance or to increase the rigidity.

The linear guideways are available in the two different preload classes  $K_0$  or  $K_1$ , see table below.

The preload influences the rigidity, precision and torque resistance and also affects the service life and displacement force.

The radial clearance for the respective preload classes are listed below.

Degree of preload	Preload class	Preload
No clearance	$K_0$	0
Small preload	$K_1$	$0,02 \times C^*$

\*C is the dynamic load capacity.

Size	Radial clearance of the preload classes $\mu$	
	$K_0$ Impact free and easy movement	$K_1$ Small moments, one rail application, low vibrations
15	-3 to +3	-8 to -4
20	-3 to +3	-8 to -4
25	-4 to +4	-10 to -5
30	-4 to +4	-11 to -5
35	-5 to +5	-12 to -6
45	-6 to +6	-15 to -7
55	-7 to +7	-19 to -8

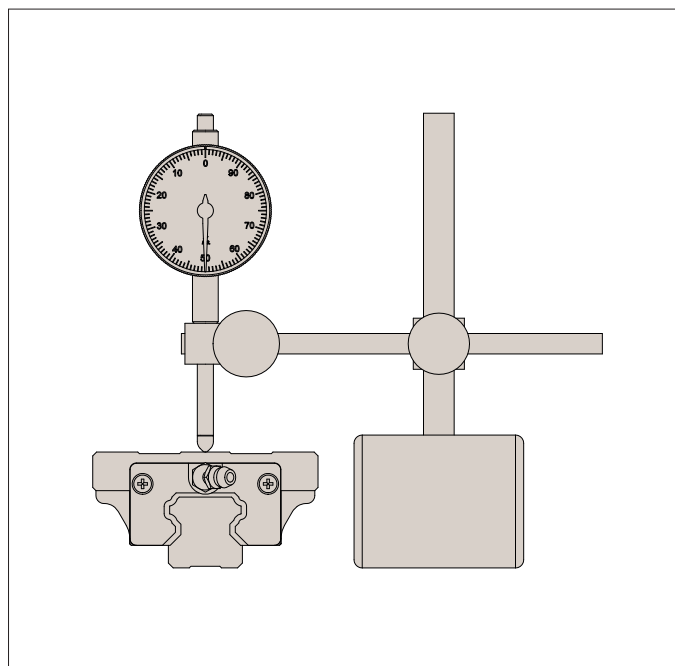

Precision means the guide accuracy or the maximum deviation of the carriage based on the side and support surfaces during the movement along the rails.

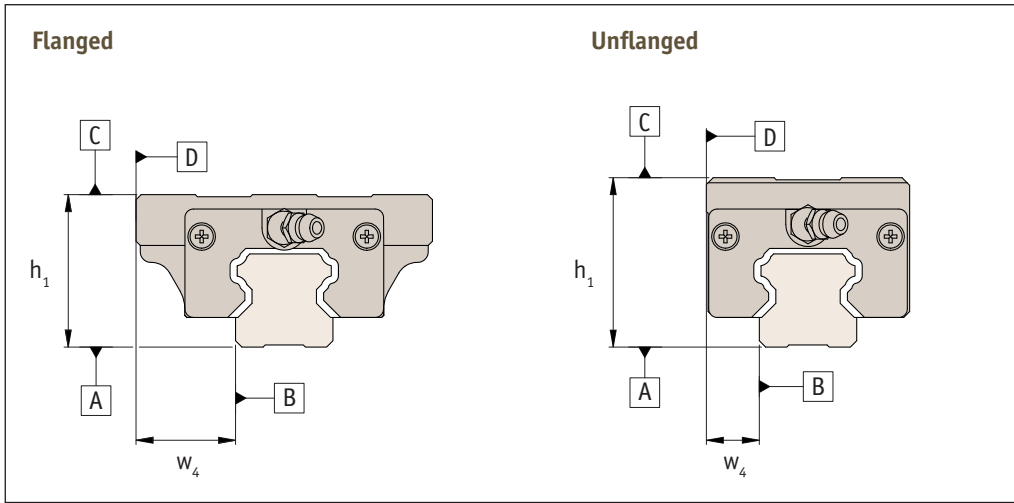

	Normal Precision (N)	H Precision (H)	P Precision (P)
Height tolerance $h_1$	$\pm 0,1$	$\pm 0,4$	0
Width tolerance $w_4$			-0,04
Guide accuracy of raceway C based on surface A	$\delta C$ see graph below		
Guide accuracy of raceway D based on surface B	$\delta D$ see graph below		

### Running tolerances

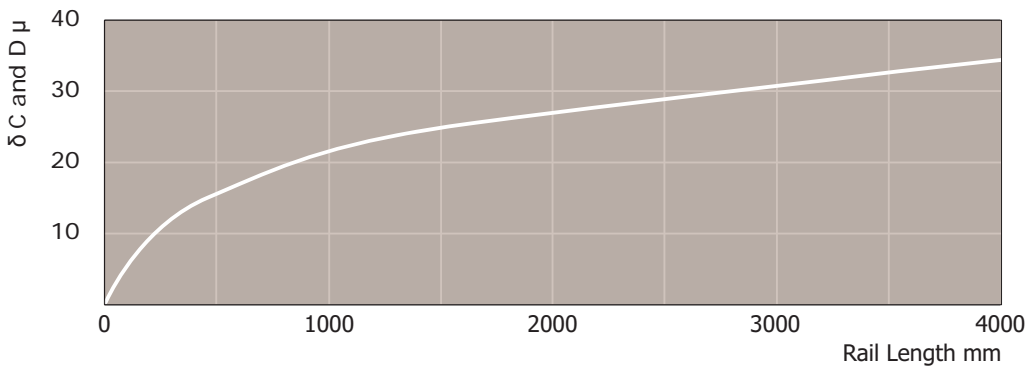



### Lubrication

Linear guideway rails must generally be lubricated before commissioning. They can be lubricated with oil or grease. The correct lubricant selection has a large influence on the service life and the function of the rail, insufficient lubrication and tribocorrosion can ultimately lead to total failure.

As well as reducing friction and wear, lubricants also serve as sealant, noise reducer and corrosion protection for the linear guide. Different lubricants for special applications are available upon request (e.g. lubricant with FDA approval for use in the food industry).

Our linear guideways are coated with an anti-corrosion resistant oil at the factory. This coating needs to be removed prior to installation, then lubricated as follows:

### Important instructions for lubrication

- Linear guideways must be lubricated for operation.
- The carriage must be moved back and forth during lubrication.
- The lubricant is inserted through a lubrication nipple.
- There should be a thin film of lubricant on the rail surface at all times.
- Primary lubricated systems have an increased displacement resistance.
- Please contact us if oil lubrication is used for vertical use.
- If the stroke is <2 or >15 times the carriage length, the lubrication intervals should be reduced.

### Grease lubrication

We recommend the use of a lithium emulsified lubricant NLGI Class 2 for lubrication.

### Oil lubrication

We recommend a synthetic oil for operating temperatures between 0°C and +70°C.

### Relubrication

- Relubrication of the system must be done before the lubricant used has become dirty or shows signs of discolouration.
- Relubrication should be performed at operating temperature. The carriage must be moved back and forth during re-lubrication.
- If the stroke is <2 or >15 times the carriage length, the lubrication intervals should be more frequent.

### Lubrication intervals

Operating speed, stroke length and ambient conditions influence the selection of time between lubrication intervals. Establishing a safe lubrication interval is based solely on the applications and conditions. However, a lubrication interval should not be longer than one year.

### Lubrication nipple

The following lubrication nipples are supplied.

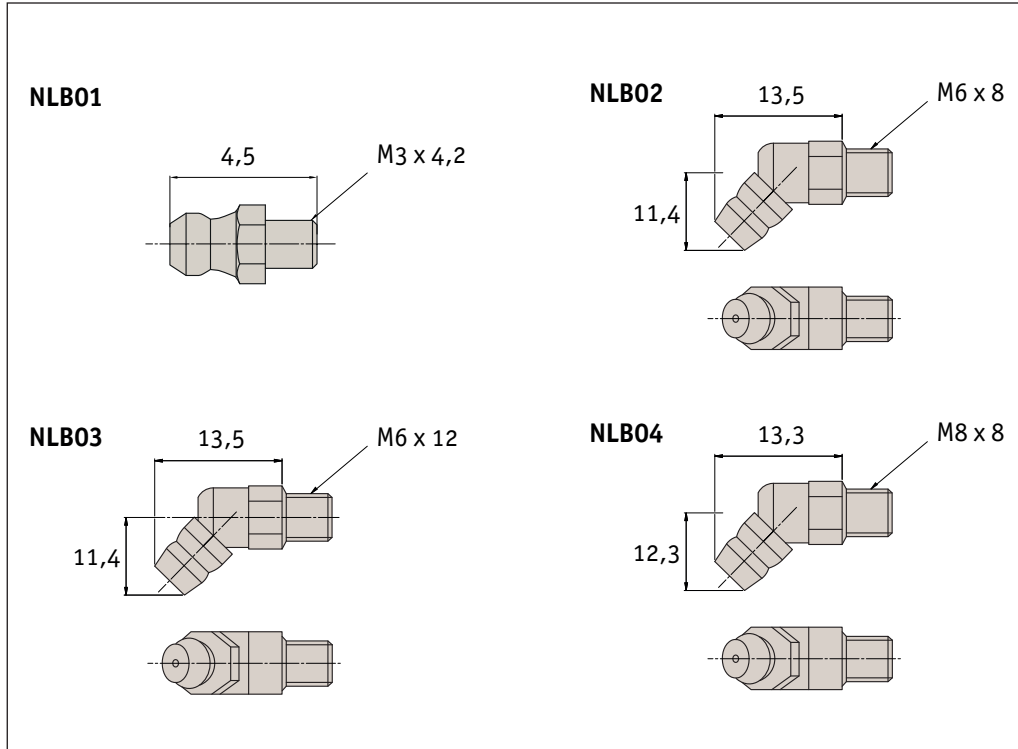

Other lubrication nipples, such as lubrication adapters with hose inlet or with quick-coupling, are available on request.

Lubrication nipple	Size
NLB01	15
NLB02	20
	25
NLB03	30
	35
NLB04	45
	55

### Surface treatment

There are numerous application-specific surface treatments available for profile rails of the linear guideway product family, for example, black oxide coating (X), hard chrome plating (XC) or nickel plating (NIC) and an FDA-approval type for use in the food industry. For more information please contact us on 0845 850 99 40.



Linear guideways have a low friction characteristic and thus low displacement resistance. The low start-up friction (breakaway force) is almost identical to the moving friction (running resistance).

The displacement resistance ( $F_m$ ) is dependent upon several factors:

- Friction of the sealing system.
- Friction of the balls with each other.
- Friction between balls and redirection.
- Rolling resistance of the balls in the running grooves.
- Resistance of lubricant in the carriage.
- Resistance caused by contamination in the lubricant.
- Preload for increased rigidity.
- Moment load.

**Resistance of the seals f**

Type	Max. seal resistance N
L1016.15	2,5 N
L1016.20	3,5 N
L1016.25	5,0 N
L1016.30	10,0 N
L1016.35	12,0 N
L1016.45	20,0 N
L1016.55	22,0 N

**Coefficient of friction  $\mu$**

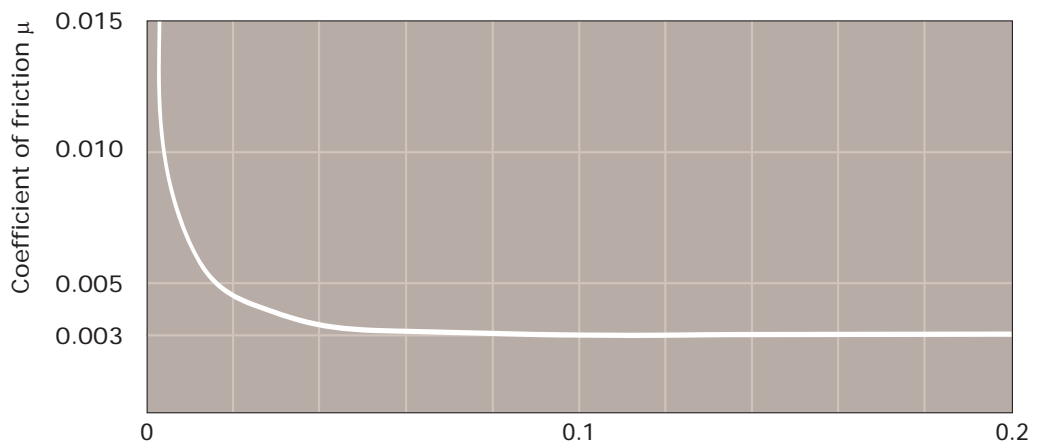

P = Load  
C = Dynamic load capacity

**Displacement resistance  $F_m$**

The following formula is used for approximate calculation of the displacement resistance. Please note that the level of preload or the viscosity of the lubricant used can also influence the displacement resistance.

$$F_m = \mu \cdot F + n \cdot f$$

- $F_m$  = Displacement resistance (N)
- $\mu$  = Coefficient of friction
- F = Load (N)
- f = Resistance of the seals (N)
- n = Number of sliders

Linear guideways have a coefficient of friction of approx.  $\mu = 0.002 - 0.003$



The given static load capacity ( $C_0$ ) for each carriage represents the maximum permissible load value, which if exceeded causes permanent deformations of the raceways and adversely affects the operating performance.

Checking the load must be done as follows:

- Through determination of the simultaneously occurring forces and moments for each carriage.
- By checking these values with the corresponding load capacities.

$$S_0 > \frac{C_0}{(F_x \cdot f_c)} \quad S_0 > \frac{C_0}{(F_y \cdot f_c)} \quad S_0 > \frac{M_x}{(M_1 \cdot f_c)} \quad S_0 > \frac{M_y}{(M_2 \cdot f_c)} \quad S_0 > \frac{M_z}{(M_3 \cdot f_c)}$$

$F_x, F_y$  = radial and axial resultants of external forces (N)

$M_1, M_2, M_3$  = external moments (Nm)

$C_0$  = static load capacity (N)

$M_x, M_y, M_z$  = maximum permissible moments in the different loading directions (Nm)

$f_c$  = contact factor (see next page)

$S_0$  = safety factor

### The safety factors

The safety factor  $S_0$  can lie on the lower given limit if the forces can be determined with sufficient precision. If impacts and vibrations affect the system, overloads might occur, then the higher value should be selected.

Reduced safety results from simultaneously occurring forces and moments.

For more information please contact our technical department.

Operating conditions	$S_0$
Normal operation	1,0 ~ 1,5
Loading with vibration or shock effect	1,5 ~ 2,0
Loading with strong vibration or impacts	2,0 ≥ 3,5



### Calculation of service life

The dynamic load capacity  $C$  is a conventional variable used for calculating the service life. This load corresponds to a nominal service life of 50 Km. The relationship between calculated service life  $L_{Km}$  (in Km), dynamic load capacity  $C$  (in N) and equivalent load  $P$  (in N) is given in the formula below.

$$L_{Km} = \left( \frac{C}{P} \cdot \frac{f_c \cdot f_t}{f_i} \right)^3 \cdot 50 \text{ Km}$$

$f_c$  = Contact factor

$f_i$  = Application coefficient

$f_t$  = Temperature factor

$C$  = Dynamic load (N)

$P$  = See below (N)

The equivalent load  $P$  corresponds in its effects to the sum of the forces and moments working simultaneously on a slider. If these different load components are known,  $P$  results from the formula below.

$$P = |F_x| + |F_y| + \left( \frac{|M_1|}{M_x} + \frac{|M_2|}{M_y} + \frac{|M_3|}{M_z} \right) C_0$$

### Contact factor $f_c$

The contact factor  $f_c$  refers to applications in which several carriages pass the same rail section. If two or more carriages are moved over the same point on a rail, the static and dynamic loading values must be multiplied with the numbers from the table below.

Number of carriages	1	2	3	4	5
$f_c$	1	0,81	0,72	0,66	0,61

### Application coefficient $f_i$

The application coefficient  $f_i$  can be understood as the dynamic safety factor. Refer to the table below for the values.

Operating conditions	Speed	$f_i$
Neither external impacts nor vibrations	Low speed $V \leq 15$ m/min.	1 - 1,5
Light impacts or vibrations	Average speed $< V \leq 60$ m/min.	1,5 - 2
Average and high external impacts or vibration	High speed $V > 60$ m/min.	2 - 3,5

### Temperature factor $f_t$

If the temperature affecting the system exceeds 100°C, the temperature factor  $f_t$  must be included in the service life calculation.

Note 1: For temperatures above 80°C, the seals and end caps must be designed for higher thermal resistance.

Note 2: Special processing to ensure the movement of the guides is required for temperatures above 120°C.

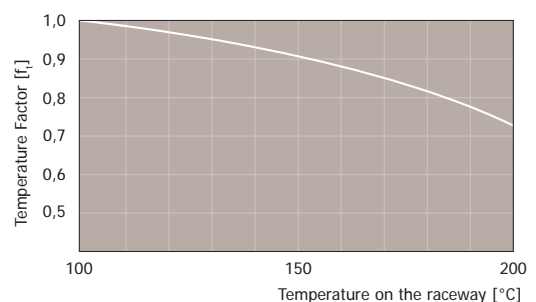

### Installation examples

The following drawings illustrate some assembly examples for rail/carriage combinations corresponding to the structure of various machine frames.

#### Example 1

Assembly of carriage and rail on shoulder edges

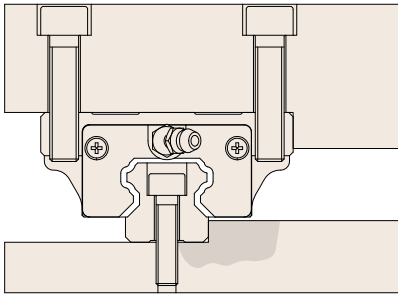

#### Example 2

Securing carriage and rail using set screws

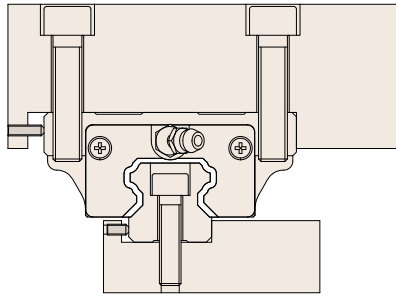

#### Example 3

Securing carriage and rail using pressure plates

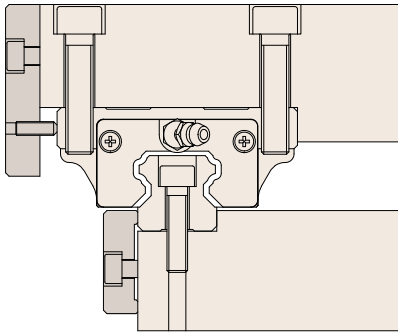

#### Example 4

Securing carriage and rail using taper gibs

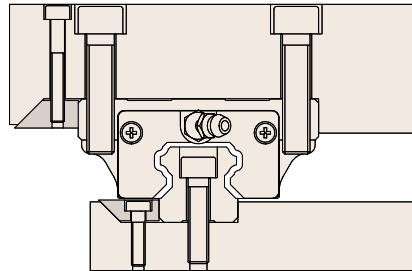

#### Example 5

Securing carriage and rail using bolts

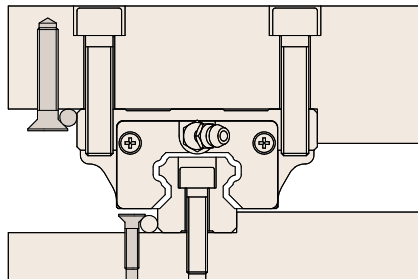



The given radii and shoulder heights in the table must be observed when assembling rails and carriages on the stop edges to ensure perfect seating of carriages or guideways.

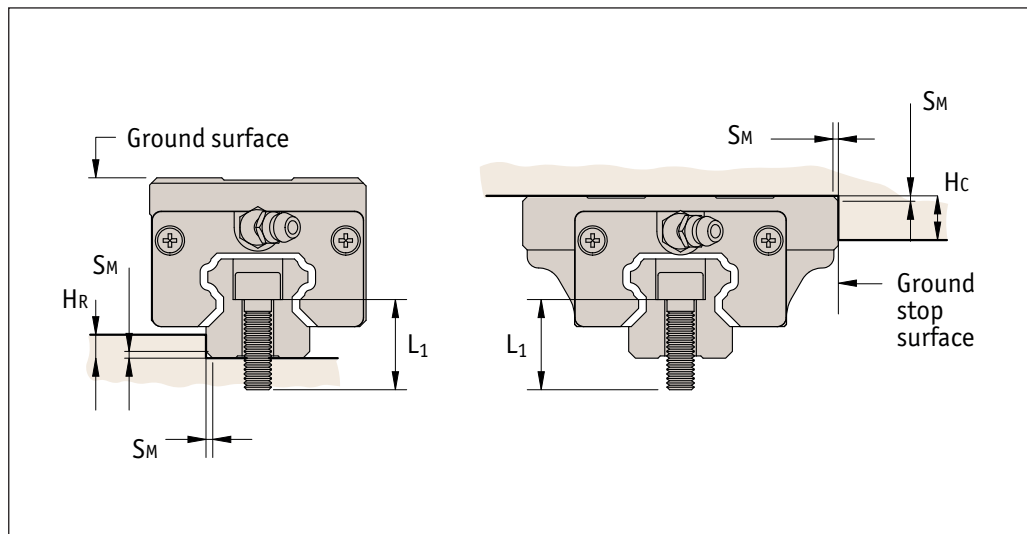

Size	SM	HR	Hc	L <sub>1</sub>
15	0,6	3,1	5	M4 x 16
20	0,9	4,3	6	M5 x 20
25	1,1	5,6	7	M6 x 25
30	1,4	6,8	8	M8 x 30
35	1,4	7,3	9	M8 x 30
45	1,6	8,7	11	M12 x 40
55	1,6	11,8	12	M14 x 45

Values in mm. HR\* is the maximum height when using side seal on carriage.

### Assembly precision

The maximum permissible deviations of the rail surfaces for assembly are given in the following drawing and the table below.

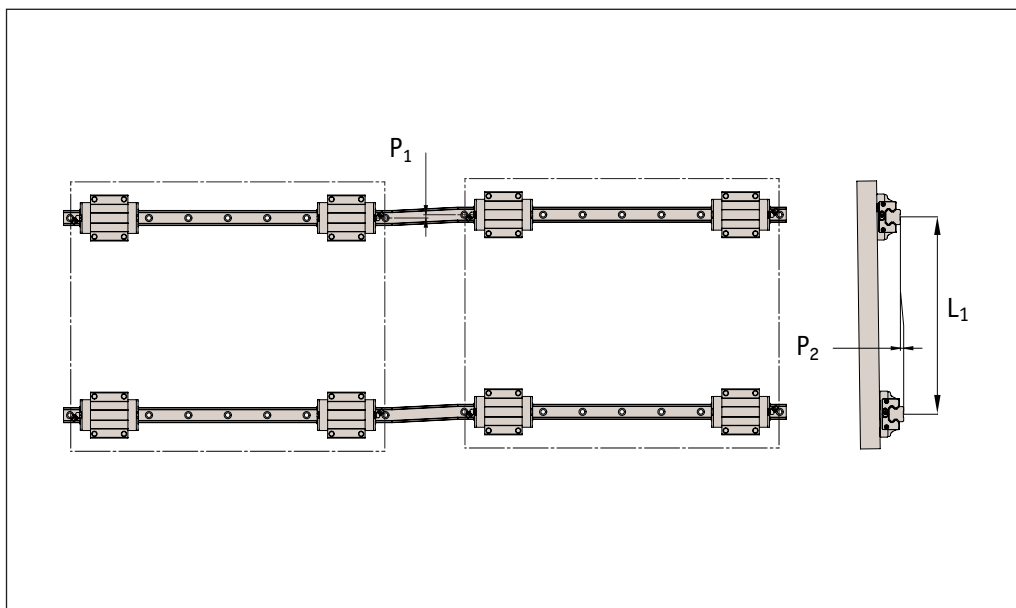

Size	Permissible tolerance for parallelism $P_1 \mu$		$P_2 = L_1 \times$ (calculation factor)	
	$K_1$	$K_0$	Calculator factor (x) $P_2 \mu$	
			$K_1$	$K_0$
15	18	25	0,17	0,26
20	20	25	0,17	0,26
25	22	30	0,17	0,26
30	30	40	0,22	0,34
35	35	50	0,30	0,42
45	40	60	0,34	0,50
55	50	70	0,42	0,60

The bolt sizes to be used and optimum tightening torques for rail assembly are listed in the table below.

Bolt	Tightening torque $M_t$ Nm	
	Steel 10,9	Steel 12,9
M 4	4,4	5,1
M 5	8,7	10
M 6	15	18
M 8	36	43
M12	125	145
M14	200	235



Assembly process

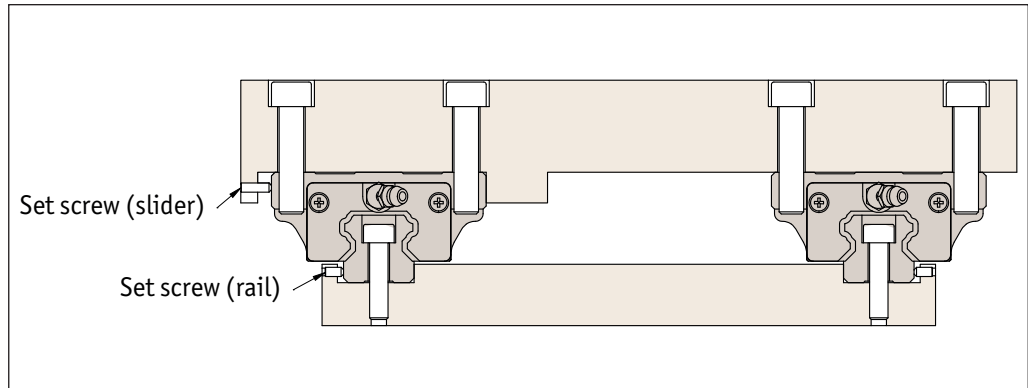

Fixing guide rails 1

Whet the assembly surface with a whetstone and also remove burrs, unevenness and dirt. Note: All linear guides are preserved with anti-corrosion oil at the factory. This protection must be removed before installation. In doing so, please ensure that the surfaces are coated with low-viscosity oil for the purpose of further protection against corrosion.

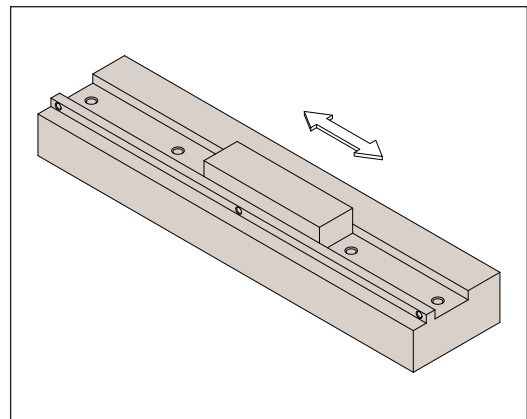

Fixing guide rails 2

Carefully lay the guide rail on the assembly surface and slightly tighten the fixing screws so that the guide rail lightly touches the assembly surface (align the guide rail along the shoulder edge of the assembly surface). Note: The fixing screws of the linear guide must be clean. Check if the fixing holes are located in the correct place when you insert the bolts. A forced tightening of a fixing screw in an offset hole can negatively affect accuracy.

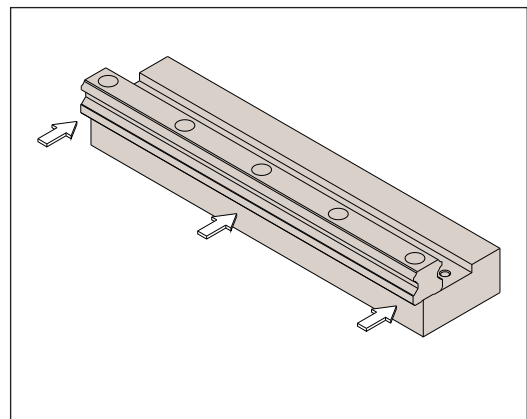

Fixing guide rails 2 continued

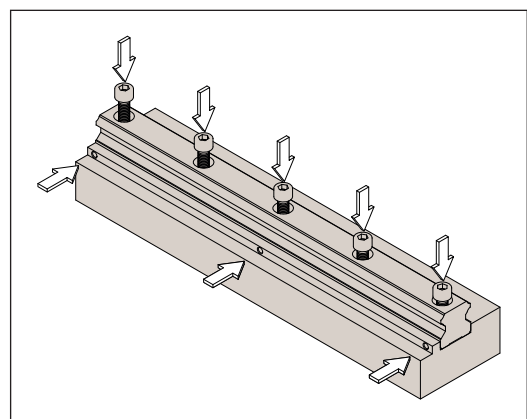

### Fixing guide rails 3

Tighten the thrust bolts on the guide rail until there is close contact on the side stop surface.

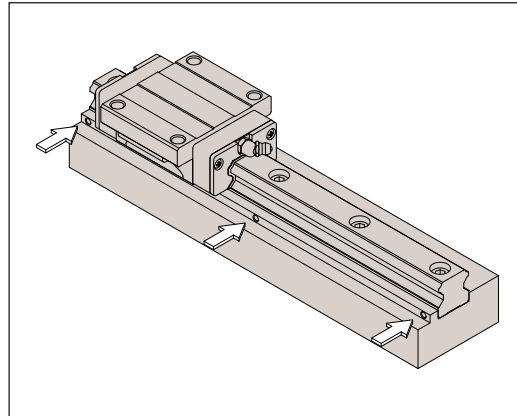

### Fixing guide rails 4

Tighten the fixing screws with a torque wrench to the prescribed torque.

Note: For a high degree of accuracy, the fixing screws of the guide rail must be tightened in sequence outward from the centre.

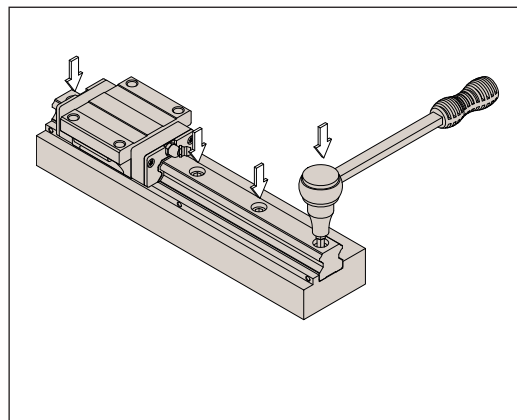

### Fixing guide rails 5

Assemble the other rails in the same manner to complete the installation of the guide rails.

### Table assembly 1

Set the table carefully on the carriage and tighten the fixing screws only lightly.

### Table assembly 2

Press the carriage on the main guide side with the thrust bolts against the shoulder edge of the table and position the table.

### Table assembly 3

Tighten the fixing screws on the main side and the lateral side completely tight to finish the installation. Note: To attach the table uniformly, tighten the fixing screws diagonally (1, 2, 3, 4).

This method saves time when straightening the guide rail and makes the manufacture of positioning pins unnecessary, which considerably reduces assembly time.

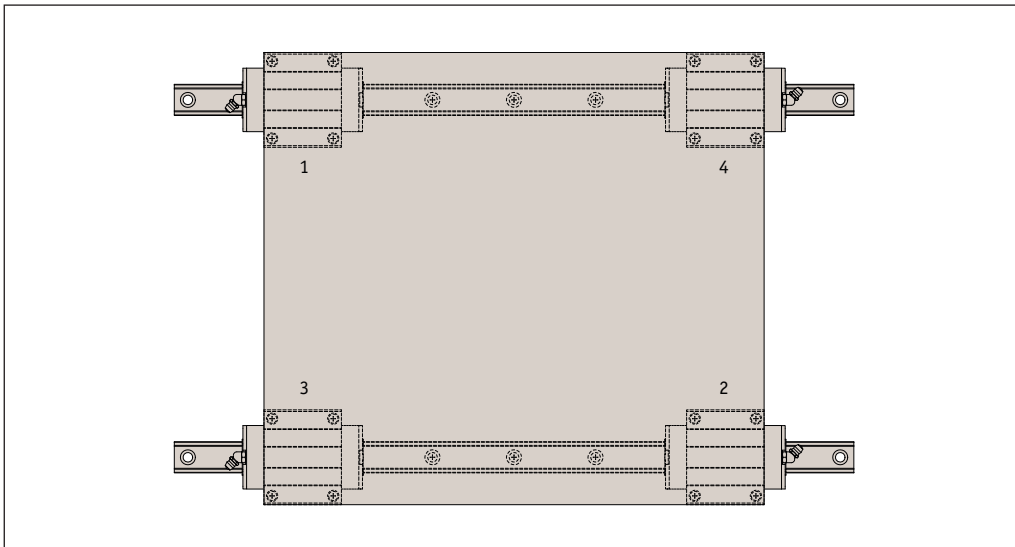



**Joining rails**

Guide rails longer than the one part maximum length are put together from two or more rails. When putting guide rails together, ensure the register marks are positioned correctly.

