

All of our rod ends incorporate either a plain spherical bearing, ball bearing, or roller bearing. Below is an overview of each type.

### Plain spherical bearings

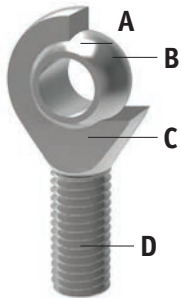

- A** Made from Polyamid-PTFE-fibreglass-compound, maintenance free, absorbs any foreign particles
- B** Ball made of bearing steel, hardened, ground, polished and hard chromium plated, ensures reliable corrosion protection
- C** No clearance - radial clearance 0-10µm
- D** All rod ends housings made of forged steel, tempered, extremely high loads resistant

### Ball and roller bearings

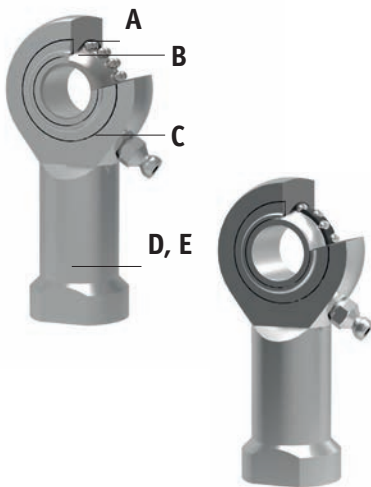

- A** Radial clearance: 10-30µm, low friction
- B** Inner ring made of bearing steel, hardened ball grooves polished
- C** Shields on both sides protect against rough dirt penetration
- D** All rod ends housings are made of forged steel, case hardened bearing race
- E** Low maintenance due to long-term greasing, especially suitable for high speed large swiveling angles or rotating movements

### Rod ends and water



#### Stainless steel versions

Most of our rod ends are available in stainless steel as standard

High grade AISI 316 stainless steel available on request

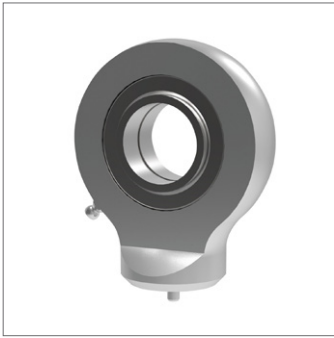

## R3620

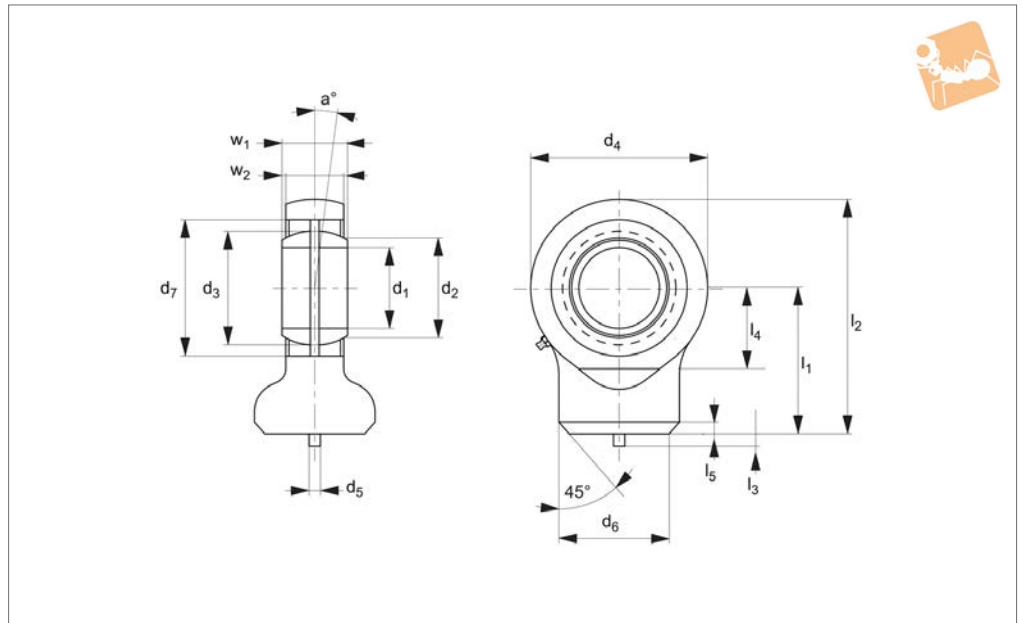

### Material

Housing: forged steel (st 52-3).  
Steel on steel bearing requiring lubrication.

Spherical plain bearing.

### Technical Notes

Sizes up to 12 not regreasable, rod ends

series E to DIN ISO 12240-4.

### Tips

For weld-on piston rod ends.

Order No.	d <sub>1</sub>	l <sub>1</sub>	d <sub>2</sub>	d <sub>3</sub>	d <sub>4</sub>	d <sub>5</sub>	d <sub>6</sub>	d <sub>7</sub>	Weight g
R3620.010	10	24	13.2	16	29	3	15	19	41
R3620.012	12	27	15	18	34	3	17.5	22	66
R3620.015	15	31	18.4	22	40	4	21	26	120
R3620.017	17	35	20.7	25	46	4	24	30	190
R3620.020	20	38	24.2	29	53	4	27.5	35	230
R3620.025	25	45	29.3	35.5	64	4	35.5	42	430
R3620.030	30	51	34.2	40.7	73	4	40	47	640
R3620.035	35	61	39.8	47	82	4	47	55	960
R3620.040	40	69	45.0	53	92	4	52	62	1300
R3620.045	45	77	50.8	60	102	6	58	68	1800
R3620.050	50	88	55.9	66	112	6	62	75	2500
R3620.060	60	100	66.8	80	135	6	70	90	3900
R3620.070	70	115	77.9	92	160	6	80	105	6600
R3620.080	80	141	89.4	105	180	6	95	120	8700

Order No.	Dyn. load C <sub>0</sub> N max.	l <sub>2</sub>	l <sub>3</sub>	l <sub>4</sub>	l <sub>5</sub>	Static load C <sub>0</sub> kN max.	w <sub>1</sub>	w <sub>2</sub>	a°
R3620.010	8.15	38.5	6	15.0	2	12.48	9	7	12
R3620.012	10.8	44	6	18.0	2	17.28	10	8	11
R3620.015	17.00	51	6	20.0	2.5	25.60	12	10	8
R3620.017	21.20	58	6	23.0	3	32.00	14	11	10
R3620.020	30.00	64.5	6	27.5	3	43.20	16	13	9
R3620.025	48.00	77	6	33	4	57.60	20	17	7
R3620.030	62.00	87.5	6	37.5	4	76.00	22	19	6
R3620.035	80.00	102	6	43	4	100.00	25	21	6
R3620.040	100.00	115	6	48	5	124.80	28	23	7
R3620.045	127.00	128	6	52.0	5	166.40	32	27	7
R3620.050	156.00	144	6	59.0	6	200.00	35	30	6
R3620.060	245.00	167.5	6	72.5	8	312.00	44	38	6
R3620.070	315.00	195	6	86	10	408.00	49	42	6
R3620.080	400.00	231	6	98	10	496.00	55	47	6

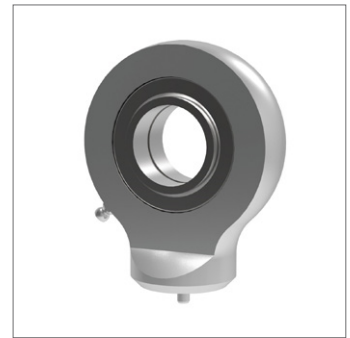
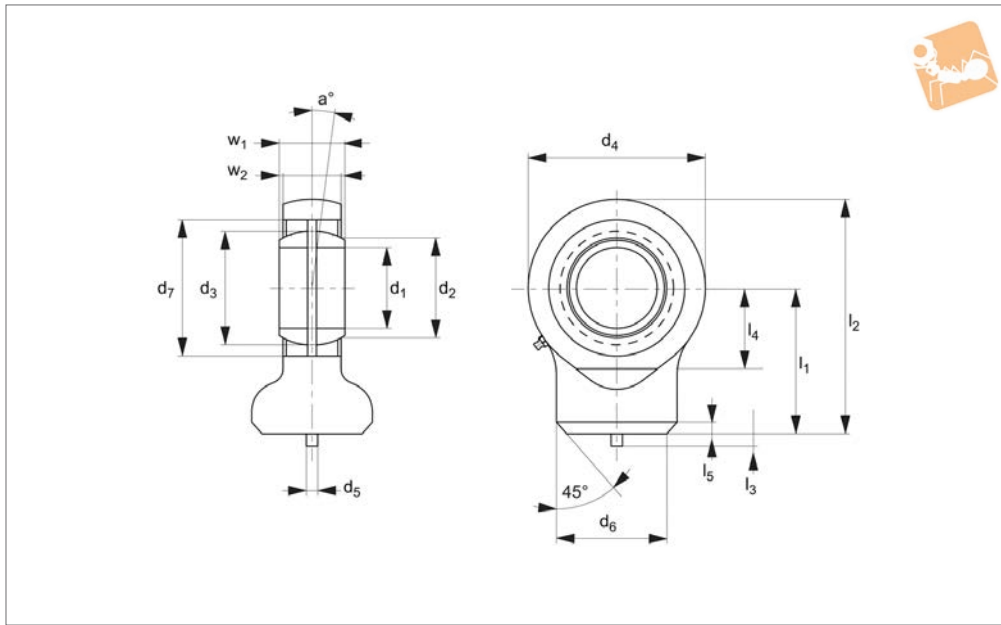

### R3621

ROD ENDS

#### Material

PTFE fabric.

Housing: stainless steel (AISI 316).

Bearing stainless steel (AISI 420C) and

Order No.	$d_1$ tol. M7	$l_1$	$d_2$	$d_3$	$d_4$	$d_5$	$d_6$	$d_7$	Weight g
R3621.020	20	38	24.1	29	53	4	27.5	35	250
R3621.025	25	45	29.3	35.5	64	4	33.5	42	450
R3621.030	30	51	34.2	40.7	73	4	40	47	675
R3621.035	35	61	39.7	47	82	4	47	55	950
R3621.040	40	69	45.0	53	92	4	52	62	1400
R3621.045	45	77	50.7	60	102	6	58	68	1910
R3621.050	50	88	56.0	66	112	6	62	75	2650

Order No.	Dyn. load $C_0$ N max.	$l_2$	$l_3$	$l_4$	$l_5$	Static load $C_0$ N max.	$w_1$	$w_2$	$a$ °
R3621.020	30.00	64.5	6	27.5	3	54.00	16	13	9
R3621.025	48.00	77	6	33	4	72.00	20	17	7
R3621.030	62.00	87.5	6	37.5	4	95.00	22	19	6
R3621.035	80.00	102	6	43	4	125.00	25	21	6
R3621.040	100.00	115	6	48	5	156.00	28	23	7
R3621.045	127.00	128	6	52.0	5	208.00	32	27	7
R3621.050	156.00	144	6	59.0	6	250.00	35	30	6

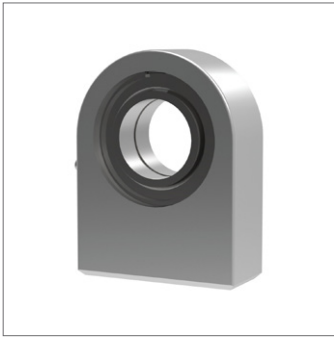

## R3622

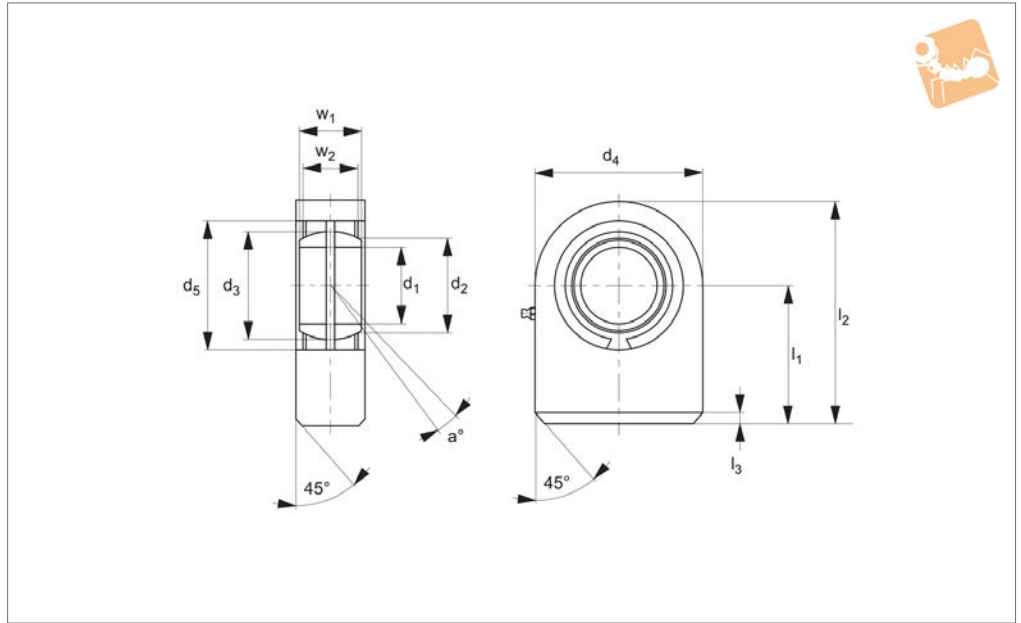

### Material

Housing: forged steel (st 52-3), steel on steel bearing requiring lubrication, spherical plain bearing.

71412

### Tips

Rod ends with rectangular surface for weld-on, spherical plain bearings fixed with snap rings.

### Technical Notes

Fitted with hydraulic grease nipple to DIN

Order No.	d <sub>1</sub> tol. M7	l <sub>1</sub>	d <sub>2</sub>	d <sub>3</sub>	d <sub>4</sub>	d <sub>5</sub>	Weight g
R3622.020	20	38	24.1	29.0	50	35	350
R3622.025	25	45	29.3	35.5	55	42	530
R3622.030	30	51	34.2	40.7	65	47	870
R3622.035	35	61	39.7	47.0	83	55	1500
R3622.040	40	69	45	53.0	100	62	2400
R3622.045	45	77	50.7	60.0	110	68	3400
R3622.050	50	88	56	66.0	123	75	4400
R3622.060	60	100	66.8	80.0	140	90	7100
R3622.070	70	115	77.8	92.0	164	105	10500
R3622.080	80	141	89.4	105	180	120	15000
R3622.090	90	150	98.1	115	226	130	23500
R3622.100	100	170	109.5	130	250	150	31500
R3622.110	110	185	121.2	140	295	160	48500
R3622.120	120	210	135.5	160	360	180	79000

Order No.	Dyn. load C kN max.	l <sub>2</sub>	l <sub>3</sub>	Static load C <sub>0</sub> kN max.	w <sub>1</sub>	w <sub>2</sub>	a °
R3622.020	30.00	63.0	2	67.00	19	16	9
R3622.025	48.00	72.5	2	69.50	23	20	7
R3622.030	62.00	83.5	2	118.00	28	22	6
R3622.035	80.00	102.5	2	196.00	30	25	6
R3622.040	100.00	119	3	300.00	35	28	7
R3622.045	127.00	132	3	380.00	40	32	7
R3622.050	156.00	149.5	3	440.00	40	35	6
R3622.060	245.00	170	4	570.00	50	44	6
R3622.070	315.00	197	4	695.00	55	49	6
R3622.080	400.00	231	4	780.00	60	55	6
R3622.090	490.00	263	4	1340.00	65	60	5
R3622.100	610.00	295	4	1500.00	70	70	7
R3622.110	655.00	332.5	4	2160.00	80	70	6



# Hydraulic Rod Ends

weld-on base

## Rod Ends

Order No.	Dyn. load C kN max.	$l_2$	$l_3$	Static load $C_0$ kN max.	$w_1$	$w_2$	$a$
R3622.120	950.00	390	4	3250.00	90	85	6

ROD ENDS

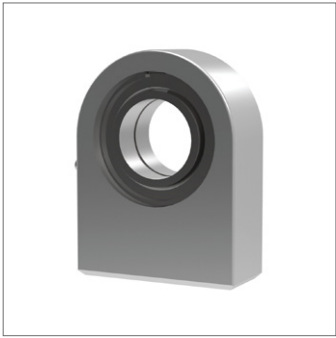

R3623

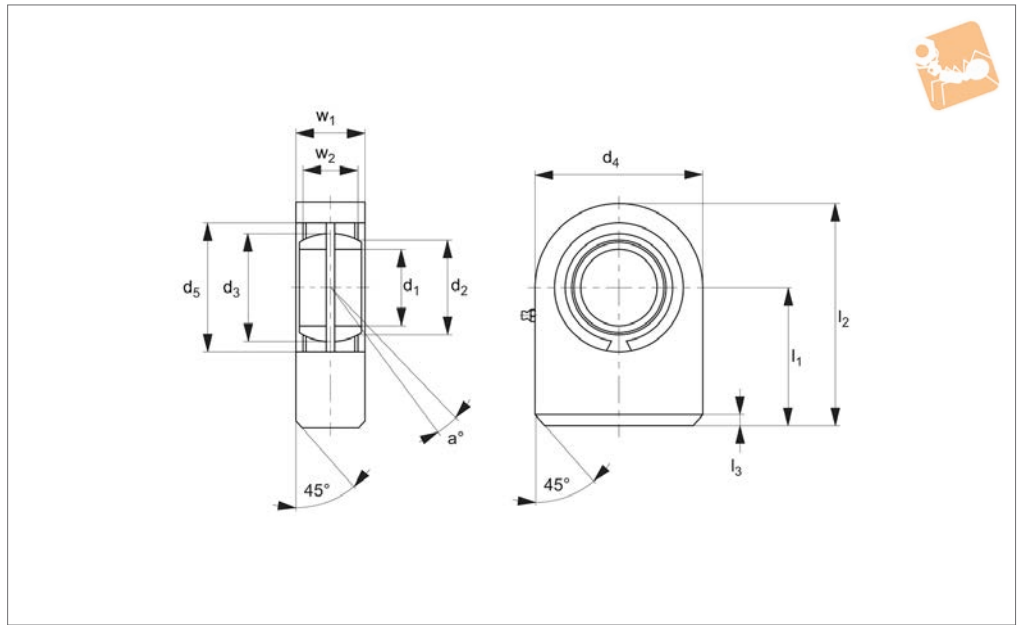

**Material**

Housing: stainless steel (AISI 316).  
Bearing: stainless steel (AISI 420C) and

PTFE fabric.

Order No.	d <sub>1</sub> tol. M7	l <sub>1</sub>	d <sub>2</sub>	d <sub>3</sub>	d <sub>4</sub>	d <sub>5</sub>	Weight g
R3623.020	20	38	24.1	29.0	50	35	325
R3623.025	25	45	29.3	35.5	55	42	500
R3623.030	30	51	34.2	40.7	65	47	825
R3623.035	35	61	39.7	47.0	83	55	1475
R3623.040	40	69	45	53.0	100	62	2480
R3623.045	45	77	50.7	60.0	110	68	3450
R3623.050	50	88	56	66.0	123	75	4450

Order No.	Dyn. load C kN max.	l <sub>2</sub>	l <sub>3</sub>	Static load C <sub>0</sub> kN max.	w <sub>1</sub>	w <sub>2</sub>	a °
R3623.020	30.00	63.0	2	67.00	19	16	9
R3623.025	48.00	72.5	2	69.50	23	20	7
R3623.030	62.00	83.5	2	118.00	28	22	6
R3623.035	80.00	102.5	2	196.00	30	25	6
R3623.040	100.00	119	3	300.00	35	28	7
R3623.045	127.00	132	3	380.00	40	32	7
R3623.050	156.00	149.5	3	440.00	40	35	6



# Hydraulic Rod Ends with female thread

## Rod Ends

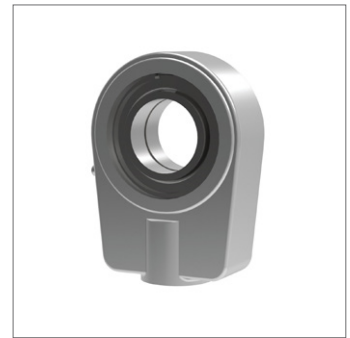
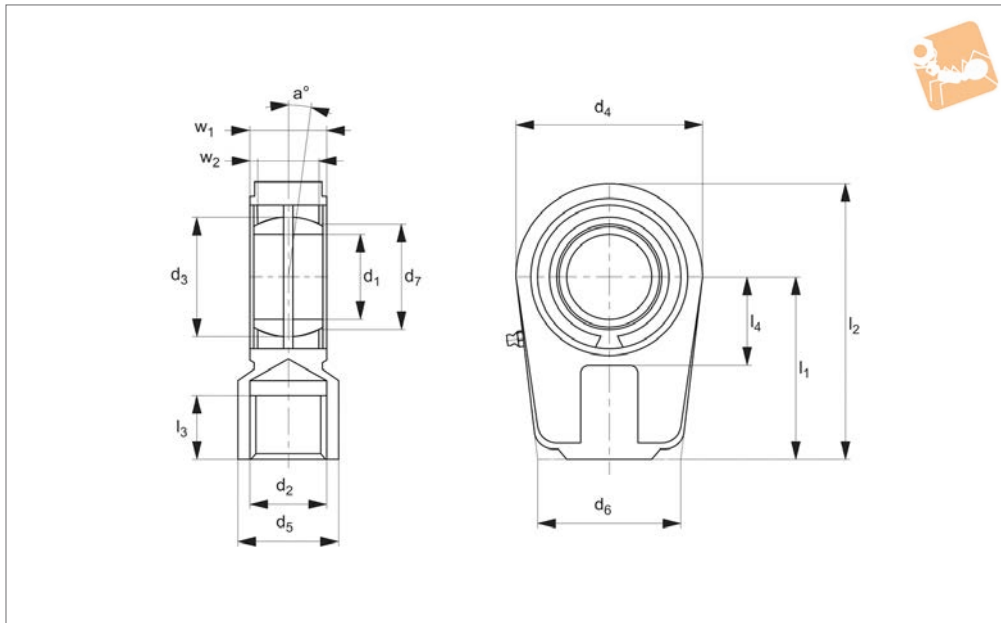

**R3624**

ROD ENDS

### Material

Housing: Up to size 60 - Heat-treated steel (C45).

From size 70 cast iron (GS400).

Steel on steel bearing requiring lubrication, spherical plain bearing.

### Technical Notes

Fitted with hydraulic grease nipples to DIN71412, rod ends with short thread, particularly suited to hydraulic cylinders. Spherical plain bearing fixed with snap rings.

### Tips

For use with shortest relay distances and maximum stroke utilization.

Order No.	d <sub>1</sub> tol. M7	l <sub>1</sub>	d <sub>2</sub> tol. 6H	d <sub>3</sub>	d <sub>4</sub>	d <sub>5</sub>	d <sub>6</sub>	d <sub>7</sub>	Dyn. load C kN max.	Weight g
R3624.020	20	50	M16x1,5	29	56	25	46	24.2	30.00	430
R3624.025	25	50	M16x1,5	35.5	56	25	46	29.3	48.00	480
R3624.030	30	60	M22x1,5	40.7	64	32	50	34.2	62.00	740
R3624.035	35	70	M28x1,5	47	78	40	66	39.8	80.00	1200
R3624.040	40	85	M35x1,5	53	94	49	76	45	100.00	2000
R3624.050	50	105	M45x1,5	66	116	61	90	55.9	156.00	3800
R3624.060	60	130	M58x1,5	80	130	75	120	66.8	245.00	5400
R3624.070	70	150	M65x1,5	92	154	86	130	77.9	245.00	5400
R3624.080	80	170	M80x2,0	105	176	105	160	89.4	400.00	12000
R3624.090	90	210	M100x2,0	115	206	124	180	98.1	490.00	21500
R3624.100	100	235	M110x2,0	130	230	138	200	109.5	610.00	27500
R3624.110	110	265	M120x3,0	140	265	152	220	121.2	655.00	40500
R3624.120	120	310	M130x3,0	160	340	172	257	135.5	950.00	76000

Order No.	l <sub>2</sub>	l <sub>3</sub>	l <sub>4</sub>	Static load C <sub>0</sub> kN max.	w <sub>1</sub>	w <sub>2</sub>	a °
R3624.020	80	17	25	72.00	19	16	9
R3624.025	80	17	28	72.00	23	20	7
R3624.030	94	23	30	106.00	28	22	6
R3624.035	112	29	38	153.00	30	25	6
R3624.040	135	36	45	250.00	35	28	7
R3624.050	168	46	55	365.00	40	35	6
R3624.060	200	59	65	400.00	50	44	6
R3624.070	237	66	75	400.00	55	49	6
R3624.080	265	81	80	670.00	60	55	6
R3624.090	323	101	90	980.00	65	60	5
R3624.100	360	111	105	1120.00	70	70	7
R3624.110	407.5	125	115	1700.00	80	80	6
R3624.120	490	135	140	2900.00	90	90	6

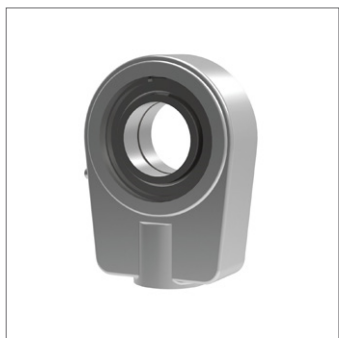

R3625

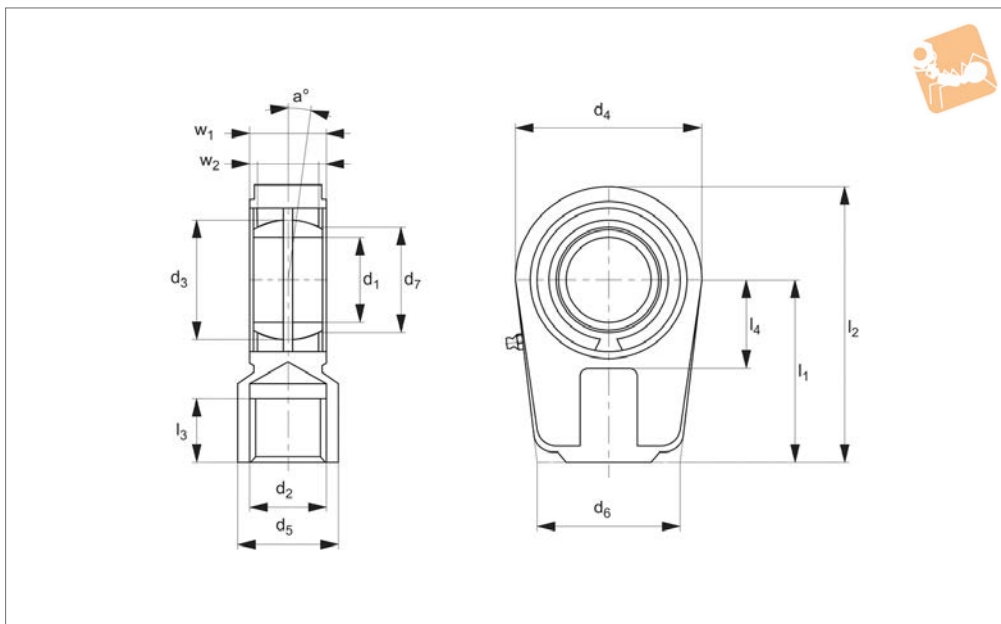

**Material**

Housing: stainless steel (AISI 316.)

Bearing stainless steel (AISI 420C) and

PTFE fabric.

**Tips**

Standard thread is right hand thread.

Order No.	d <sub>1</sub> tol. M7	l <sub>1</sub>	d <sub>2</sub> tol. 6H	d <sub>3</sub>	d <sub>4</sub>	d <sub>5</sub>	d <sub>6</sub>	d <sub>7</sub>	Dyn. load C kN max.	Weight g
R3625.020	20	50	M16x1,5	29	56	25	46	24.1	30.00	400
R3625.025	25	50	M16x1,5	35.5	56	25	46	29.3	48.00	475
R3625.030	30	60	M22x1,5	40.7	64	32	50	34.2	62.00	700
R3625.035	35	70	M28x1,5	47	78	40	66	39.7	80.00	1150
R3625.040	40	85	M35x1,5	53	94	49	76	45	100.00	2075
R3625.050	50	105	M45x1,5	66	116	61	90	56	156.00	3575

Order No.	l <sub>2</sub>	l <sub>3</sub>	l <sub>4</sub>	Static load C <sub>0</sub> kN max.	w <sub>1</sub>	w <sub>2</sub>	a °
R3625.020	80	17	25	72.00	19	16	9
R3625.025	80	17	28	72.00	23	20	7
R3625.030	94	23	30	106.00	28	22	6
R3625.035	112	29	38	153.00	30	25	6
R3625.040	135	36	45	250.00	35	28	7
R3625.050	168	46	55	365.00	40	35	6





# Hydraulic Rod Ends with female thread and locking nuts

## Rod Ends

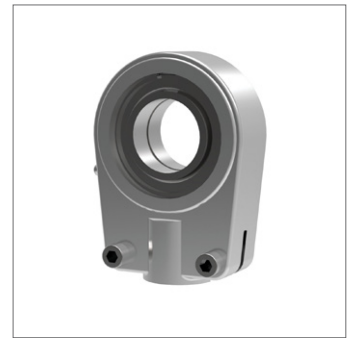

**R3626**

ROD ENDS

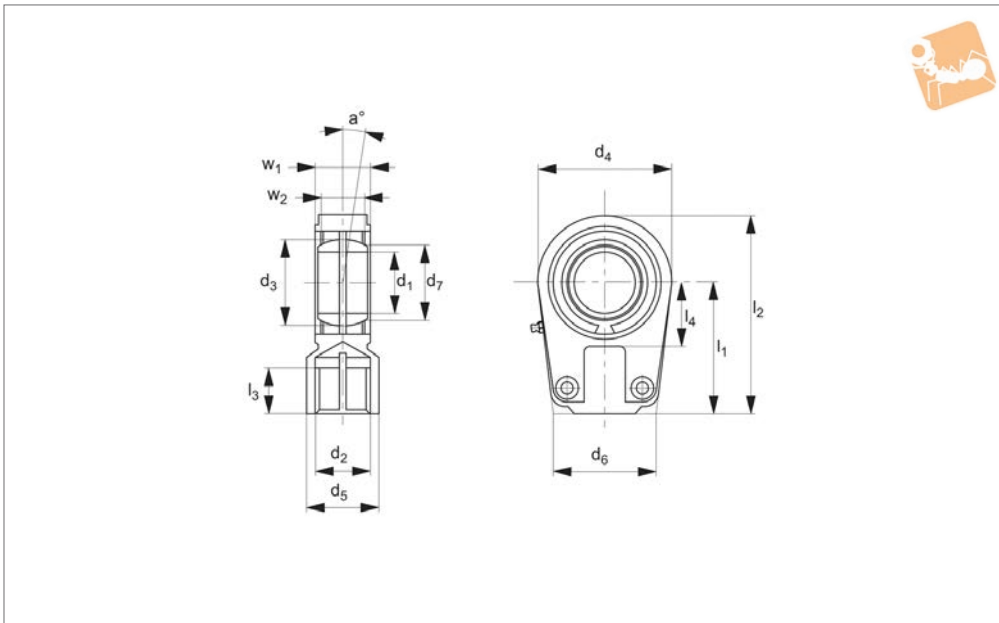

**Material**

Housing: Up to size 60 - Heat-treated steel (C45).  
From size 70 cast iron (GS400).  
Steel on steel bearing requiring lubrication.

Spherical plain bearing.

**Technical Notes**

Fitted with hydraulic grease nipples to DIN71412.  
Hex socket cap screw to DIN912-12.9,

spherical plain bearings fixed with snap rings.

**Tips**

For use with shortest relay distances and maximum stroke utilization.

Order No.	d <sub>1</sub> tol. M7	l <sub>1</sub>	d <sub>2</sub> tol. 6H	d <sub>3</sub>	d <sub>4</sub>	d <sub>5</sub>	d <sub>6</sub>	d <sub>7</sub>	Dyn. load C kN max.	Weight g
R3626.020	20	50	M16x1,5	29	56	25	46	24.2	30.00	430
R3626.025	25	50	M16x1,5	35.5	56	25	46	29.3	48.00	480
R3626.030	30	60	M22x1,5	40.7	64	32	50	34.2	62.00	740
R3626.035	35	70	M28x1,5	47	78	40	66	39.8	80.00	1200
R3626.040	40	85	M35x1,5	53	94	49	76	45	100.00	2000
R3626.050	50	105	M45x1,5	66	116	61	90	55.9	156.00	3800
R3626.060	60	130	M58x1,5	80	130	75	120	66.8	245.00	5400
R3626.070	70	150	M65x1,5	92	154	86	130	77.9	245.00	8500
R3626.080	80	170	M80x2,0	105	176	105	160	89.4	400.00	12000
R3626.090	90	210	M100x2,0	115	206	124	180	98.1	490.00	21500
R3626.100	100	235	M110x2,0	130	230	138	200	109.5	610.00	27500
R3626.110	110	265	M120x3,0	140	265	152	220	121.2	655.00	40500
R3626.120	120	310	M130x3,0	160	340	172	257	135.5	950.00	76000

Order No.	l <sub>2</sub>	l <sub>3</sub>	l <sub>4</sub>	Static load C <sub>0</sub> kN max.	w <sub>1</sub>	w <sub>2</sub>	a °
R3626.020	80	17	25	72.00	19	16	9
R3626.025	80	17	28	72.00	23	20	7
R3626.030	94	23	30	106.00	28	22	6
R3626.035	112	29	38	153.00	30	25	6
R3626.040	135	36	45	250.00	35	28	7
R3626.050	168	46	55	365.00	40	35	6
R3626.060	200	59	65	400.00	50	44	6
R3626.070	237	66	75	400.00	55	49	6
R3626.080	265	81	80	670.00	60	55	6
R3626.090	323	101	90	980.00	65	60	5
R3626.100	360	111	105	1120.00	70	70	7
R3626.110	407.5	125	115	1700.00	80	80	6
R3626.120	490	135	140	2900.00	90	90	6

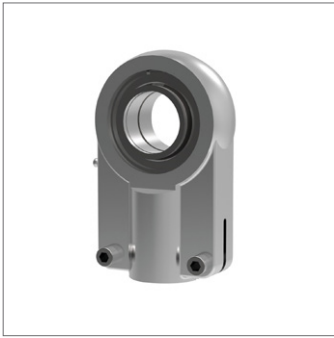

## R3628

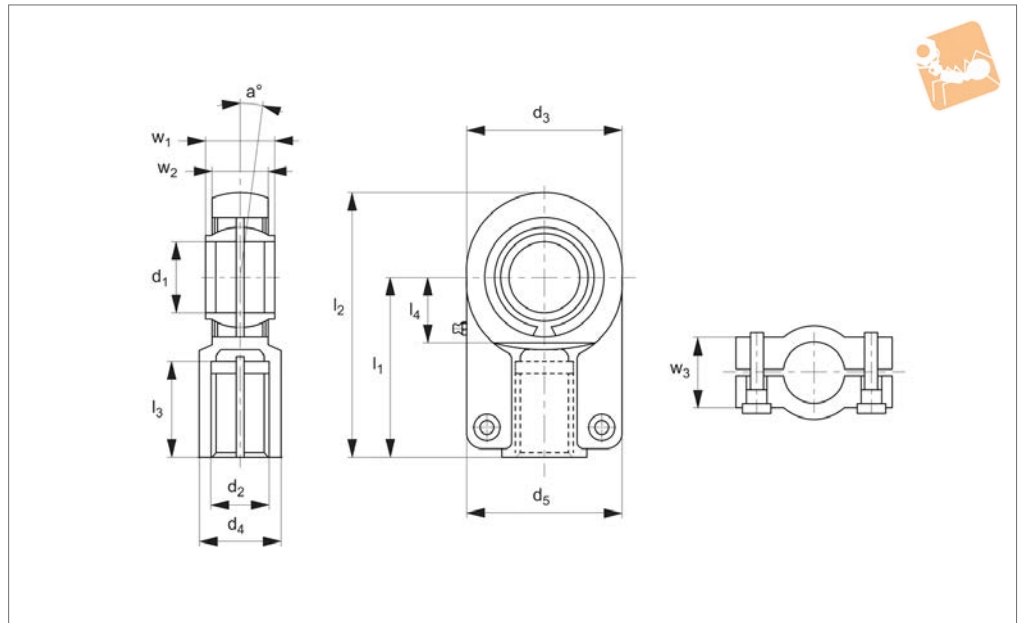

### Material

Housing: Up to size 60 - Heat-treated steel (C45).

From size 70 cast iron (GS400).

Bearing: steel on steel requiring lubrication.

For standard hydraulic cylinders, fastened by hexagon socket cap screws to DIN912-12.9.

Spherical plain bearings, regreasable, fixed with snap rings, sizes up to 12 not regreasable.

hand thread available on request.

### Technical Notes

DIN24338/ISO6982.

### Tips

Standard thread is right hand thread, left

Order No.	d <sub>1</sub> tol. H7	l <sub>1</sub>	d <sub>2</sub> tol. 6H	d <sub>3</sub>	d <sub>4</sub>	d <sub>5</sub>	Dyn. load C kN max.	l <sub>2</sub>	l <sub>3</sub>	Weight g
R3628.012	12	38	M12x1,25	32	16.5	32	10.80	54	17	100
R3628.016	16	44	M14x1,5	40	21	40	17.60	64	19	200
R3628.020	20	52	M16x1,5	47	25	47	30.00	77	23	400
R3628.025	25	65	M20x1,5	58	30	54	48.00	96	29	660
R3628.032	32	80	M27x2,0	71	38	66	67.00	118.5	37	1200
R3628.040	40	97	M33x2,0	90	47	80	100.00	146	46	2100
R3628.050	50	120	M42x2,0	109	58	96	156.00	179.5	57	4400
R3628.063	63	140	M48x2,0	136	70	114	255.00	213	64	7600
R3628.070	70	160	M56x2,0	155	80	135	315.00	245	76	9500
R3628.080	80	180	M64x3,0	168	90	148	400.00	270	86	14500
R3628.090	90	195	M72x3,0	185	100	160	490.00	296	91	17000
R3628.100	100	210	M80x3,0	210	110	178	610.00	322	96	28000
R3628.110	110	235	M90x3,0	235	125	190	655.00	364	106	32000
R3628.125	125	102	M100x3,0	260	135	200	950.00	405	113	43000

Order No.	l <sub>4</sub>	Static load C <sub>0</sub> kN max.	w <sub>1</sub>	w <sub>2</sub>	w <sub>3</sub>	a°
R3628.012	14	17.60	12	11	11	4
R3628.016	18	36.50	16	14	14	4
R3628.020	22	48.00	20	17	17	4
R3628.025	27	78.00	25	22	19	4
R3628.032	32	114.00	32	28	22	4
R3628.040	41	204.00	40	33	26	4
R3628.050	50	310.00	50	41	32	4
R3628.063	62	430.00	63	53	38	4
R3628.070	70	540.00	70	57	42	4
R3628.080	78	695.00	80	66	48	4



## Hydraulic Rod Ends with female thread and locking nuts

Rod Ends

Order No.	$l_4$	Static load $C_0$ kN max.	$w_1$	$w_2$	$w_3$	$a$ °
R3628.090	85	750.00	90	72	52	4
R3628.100	98	1060.00	100	84	62	4
R3628.110	105	1200.00	110	88	62	4
R3628.125	120	1430.00	125	102	72	4

ROD ENDS

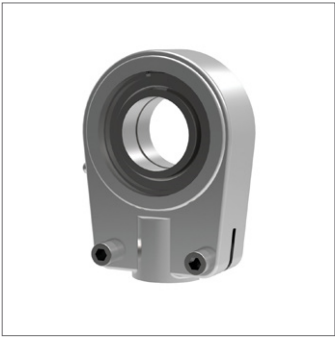

## R3627

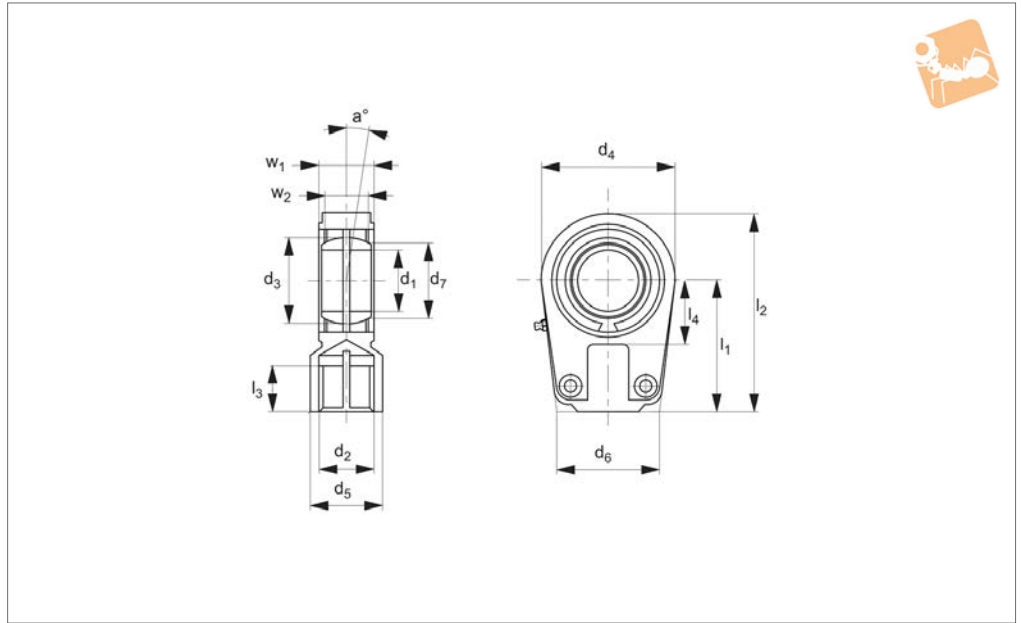

### Material

Housing: stainless steel (AISI 316).  
Bearing stainless steel (AISI 420C) and PTFE fabric.

### Technical Notes

Hex socket cap screw to DIN912-12.9.  
Spherical plain bearings fixed with snap rings, maintenance free.

### Tips

Standard thread is right hand thread.

Order No.	d <sub>1</sub> tol. M7	l <sub>1</sub>	d <sub>2</sub> tol. 6H	d <sub>3</sub>	d <sub>4</sub>	d <sub>5</sub>	d <sub>6</sub>	d <sub>7</sub>	Dyn. load C kN max.	Weight g
R3627.020	20	50	M16x1,5	29	56	25	46	24.1	30.00	400
R3627.025	25	50	M16x1,5	35.5	56	25	46	29.3	48.00	475
R3627.030	30	60	M22x1,5	40.7	64	32	50	34.2	62.00	700
R3627.035	35	70	M28x1,5	47	78	40	66	39.7	80.00	1150
R3627.040	40	85	M35x1,5	53	94	49	76	45	100.00	2075
R3627.050	50	105	M45x1,5	66	116	61	90	56	156.00	3575

Order No.	l <sub>2</sub>	l <sub>3</sub>	l <sub>4</sub>	Static load C <sub>0</sub> kN max.	w <sub>1</sub>	w <sub>2</sub>	a °
R3627.020	80	17	25	72.00	19	16	9
R3627.025	80	17	28	72.00	23	20	7
R3627.030	94	23	30	106.00	28	22	6
R3627.035	112	29	38	153.00	30	25	6
R3627.040	135	36	45	250.00	35	28	7
R3627.050	168	46	55	365.00	40	35	6



Pages 106 - 109

**Heavy Duty Rod Ends - integral spherical plain bearing**

Male and female series K rod ends, maintenance free. These are our most popular range of heavy duty rod ends.

**Sizes** Bore diameters 5mm up to 30mm.



Pages 110 - 113

**Heavy Duty Rod Ends - integral spherical plain bearing**

Male and female series E rod ends, maintenance free.

**Sizes** Bore diameters 6mm up to 60mm.



Pages 114 - 1120

**Heavy Duty Rod Ends - integral ball bearing**

Male and female series K rod ends. R3559 and R3560 have different bore sizes in relation to the thread size. All require maintenance.

**Sizes** Bore diameters 6mm up to 30mm.

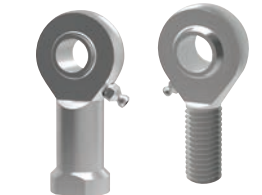

Pages 121- 123

**Heavy Duty Rod Ends - integral roller bearings**

Male and female series E rod ends, require maintenance.

**Sizes** Bore diameters 12mm up to 30mm.



Pages 129 - 135

**Stainless Steel Heavy Duty Rod Ends - integral spherical plain bearing**

Male and female rod ends maintenance free. R3565 and R3566 K series rod ends, R3567 and R3568 E series rod ends.

**Sizes** R3565 and R3566 bore diameters 5mm up to 30mm. R3567 and R3568 bore diameters 6mm up to 60mm.



Pages 136 - 138

**Low Cost Rod Ends - with spherical plain bearing**

These are our most popular male and female rod ends. Maintenance free.

**Sizes** Female-bore diameters 5mm up to 12mm; Male-bore diameters 5mm up to 16mm.

ov-rod-ends-overview-a-rnh- Updated - 28-03-2023

ROD ENDS



Pages 139 - 145

### Low Cost Rod Ends - spherical plain bearing

Male and female series E rod ends, maintenance free.

Sizes Bore diameters 6mm up to 80mm.



Pages 146 - 147

### Stainless Steel Low Cost Rod Ends - spherical plain bearing

Male and Female Series K rod ends, maintenance free.

Sizes Bore diameters 5mm up to 20mm.



Pages 150 - 157

### Plastic Rod Ends

Male and female rod ends, Series K and Series E rod ends.

Sizes Bore diameters 2mm up to 30mm.



Pages 158 - 165

### Rod Ends with Studs

Steel and Stainless steel, male and female maintenance free.

Sizes M6 up to M16.

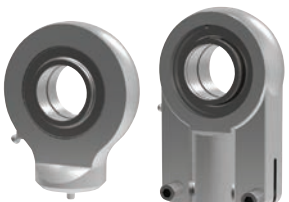

Pages 166 - 179

### Hydraulic Rod Ends - spherical plain bearings

Various options from Weld on base through to female thread, require maintenance.

Sizes Bore diameters up to 160mm.

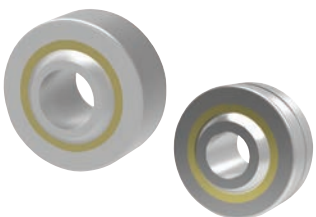

Pages 182 - 186

### Spherical Plain Bearings - steel and stainless steel

Series K and series E spherical bearings. R3640 are our lowest cost, most popular option. R3641 and stainless steel R3642 require maintenance. R3640, R3644, and stainless steel R3645 are maintenance free.

Sizes Bore diameters 5mm up to 30mm.



### Rod ends with integral maintenance-free spherical plain bearings

In many cases heavy-duty rod ends with integral spherical plain bearings are most often used. They are above all used for small swivelling or tilting movements at low speeds. They stand out for their high load capacity and can also be used for shock-like loads. The rod end ball slides on a plastic bearing shell consisting of a glass fibre-filled nylon/teflon compound. This design assures a maintenance-free rod end. Heavy-duty plain bearing rod ends have slight initial movement friction and virtually no clearance. The plastic material used has another advantage in that it can absorb many foreign particles so that no damage can occur. The balls of heavy-duty rod ends with integral spherical plain bearings are hard chrome plated. This reliable corrosion protection ensures that the function of the rod end will not be affected by a corroded ball surface under humid operating conditions.

### Rod ends with integral ball bearings

This design is especially suitable for high speeds, large swivelling angles or rotating movements with relatively low or medium loads. Prominent technical features are the low bearing friction, long-time greasing as well as the sealing against some dirt penetration (by means of shields on both sides). Under normal operating conditions the rod ends are maintenance-free.

Greasing nipples are provided for lubrication in case of rough operations and maximum loads. To avoid incompatibility with the production lubrication, we recommend lubrication with a calcium-complex-soap-grease. A special heat treatment procedure gives the rod end housing a raceway hardness adapted to the antifriction bearing, ensuring at the same time high stability with changing loads.

### Rod ends with integral roller bearings

This design based on the structure of a self-aligning roller bearing is preferably used for high speed, large tilting angles or rotating movements under high loads. Compared to rod ends with ball bearings, rod ends with self-aligning roller bearings have essentially higher basic load ratings. This design is equipped with a cage to minimise the rolling friction and heat build-up. These rod ends, with long-time lubrication are under normal operating conditions maintenance-free.

Greasing nipples are provided for lubrication in case of rough operations and maximum loads. To avoid incompatibility with the production lubrication, we recommend lubricating with a calcium-complex-soap-grease.

Shields on both sides limit dirt particles from penetrating into the bearing. The rod ends with roller bearings are, subjected to a special heat treatment to obtain a raceway hardness adapted to the antifriction bearings, ensuring at the same time a high stability with changing loads.



#### Static load capacity $C_0$ (plain bearings)

The static load capacity  $C_0$  is the radially acting static load which does not cause any permanent deformation of the components when the spherical bearing or rod end is stationary, (i.e. the load condition without pivoting, swivelling or tilting movements).

It is also a precondition here that the operating temperature must be at normal room temperature and the surrounding components must possess sufficient stability.

The values specified in the tables are determined by static tension tests on a representative number of series components at 20°C normal room temperature. The static load capacity may vary with lower or higher temperature depending on the material.

In the case of all rod ends with plain bearings, the static load rating refers to the maximum permissible static load of the rod end housing in a tensile direction up to which no permanent deformation occurs at the weakest housing cross-section. The value in the product tables has a safety factor of 1.2 times the tensile strength of the rod ends housing material.

#### Static load capacity $C_0$ (roller and ball bearings)

For our rod ends with roller and ball bearings, the static load rating is the load at which the bearing can operate at room temperature without its performance being impaired as a result of deformations, fracture, or damage to the sliding contact surfaces (max 1/10,000<sup>th</sup> of the ball diameter).

#### Dynamic load capacity $C$ (plain bearings)

Dynamic load ratings serve as values for calculation of the service life of dynamically-loaded spherical bearings and rod ends. The values themselves do not provide any information about the effective dynamic load capacity of the spherical bearing or rod end. To obtain this information, it is necessary to take into account the additional influencing factors such as load type, swivel or tilt angle, speed characteristic, max. permitted bearing clearance, max. permitted bearing friction, lubrication conditions and temperature, etc.

Dynamic load capacities depend on the definition used to calculate them. Comparison of values is not always possible owing to the different definitions used by various manufacturers, and because the load capacities are often determined under completely different test conditions.

#### Dynamic load capacity $C$ (roller and ball bearings)

For our rod ends with roller and ball bearings, the dynamic load capacity is the load at which 90% of a large quantity of identical rod ends reach 1 million revolutions before they fail (due to fatigue of the rolling surfaces).



### Permissible load

The maximum load is defined by the static basic load rating  $C_0$ . If static loads are a combination of radial and axial loads, the equivalent static load will have to be calculated.

Permissible load:

$$P_0 \leq C_0 \text{ (N)}$$

Where:  $P_0$  = Static equivalent load (kN)

Self-aligning ball bearing =  $P_0 = F_r + Y_0 \cdot F_a$

Self-aligning roller bearing =  $P_0 = F_r + 5 \cdot F_a$

$F_a$  = Axial load

$F_r$  = Radial load

$Y_0$  = Axial factor, static, see individual product pages

$C_0$  = Basic static load rating (kN), see individual product pages

### Nominal service life

Rod Ends with integral self-aligning ball bearing R3556, R3557, R3559, R3560, R3563, R3564.

Rotating:

$$G_{h_{rot.}} = 10^6 \frac{\left(\frac{C}{P}\right)^3}{60 \cdot n} \text{ (h)}$$

Oscillating:

$$G_{h_{osc.}} = 10^6 \frac{\left(\frac{C}{P \sqrt[3]{\frac{\beta}{90}}}\right)^3}{60 \cdot f} \text{ (h)}$$

Where:  $P$  = Dynamic equivalent load (kN)

Self-aligning ball bearing =  $P = F_r + Y \cdot F_a$

Self-aligning roller bearing =  $P = F_r + 9.5 \cdot F_a$

$C$  = Basic dynamic load (kN), see individual product pages

$Y$  = axial factor, dynamic, see individual product pages

$G_{h_{rot.}}$  = nominal service life for rotation (hours of operation)

$G_{h_{osc.}}$  = nominal service life for rotation (hours of operation)

$\beta$  = half of swivelling angle (degree),  $\beta = 90$  should be used for rotation. **Condition:** Swivelling angle  $\beta \leq 3^\circ$ . For swivelling angles  $\beta < 3^\circ$  we recommend the use of heavy-duty spherical plain bearing rod ends

$n$  = rotation speed (rpm)

$f$  = frequency of oscillation (rpm)

$h$  = hours

**Nominal service life**

Rod ends with integral self-aligning roller bearing R3561, R3562.

Rotating:

$$G_{h_{rot.}} = 10^6 \frac{\left(\frac{C}{P}\right)^{3,333}}{60 \cdot n} \text{ (h)}$$

Oscillating:

$$G_{h_{osc.}} = 10^6 \frac{\left(\frac{C}{P \sqrt[3]{\frac{\beta}{90}}}\right)^{3,333}}{60 \cdot f} \text{ (h)}$$

See table on page 114 for key to symbols

**Calculation example**

At the rotating side of a crank mechanism a ball or roller bearing rod end should be installed. The expected service life amounts to at least 5000 hours.

Known: rotation speed  $n = 300$  rpm, radial load  $F_r = 0,75$  kN

Selected: R3557.R008 = 4,0 kN

$$G_{h_{rot.}} = 10^6 \frac{\left(\frac{C}{P}\right)^3}{60 \cdot n}$$

$$= 10^6 \frac{\left(\frac{4,0}{0,75}\right)^3}{60 \cdot 300} = \underline{\underline{8428 \text{ h} > 5000 \text{ h}}} \quad \checkmark$$



### Permissible load

The maximum permissible load is calculated by using equation 1. If static loads are a combination of radial and axial loads, the equivalent static load will have to be calculated using equation 2.

Permissible load:

Equation 1  $P_{max.} = C_0 \cdot C_2 \cdot C_4$

Equation 2  $P = F_r + F_a \leq P_{max.}$

- Where:
- $P_{max}$  = Maximum permissible load (kN)
  - $C_0$  = static basic load (kN), see individual product pages
  - $C_2$  = Temperature factor, see below
  - $C_4$  = Factor for type of load, see below
  - $P$  = Equivalent dynamic load (kN)
  - $F_r$  = Radial load
  - $F_a$  = Axial load (kN), **condition:**  $F_a \leq 0.2 \cdot F_r$

Load factor  $C_4$ :

Constant:



$C_4$ :

1,0

Pulsating:



0,3

Alternating:

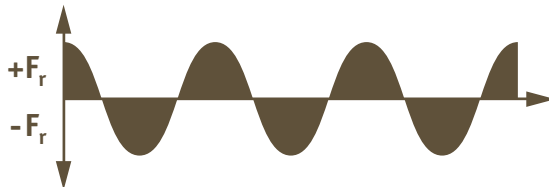

0,2

Temperature factor  $C_2$ :

Up to 60°C	1,0
60°C to 80°C	0,8
80°C to 100°C	0,7
100°C to 120°C	0,8

**Permissible sliding velocity**

The permissible sliding velocity of heavy-duty rod ends mainly depends on the load and temperature conditions. Heat generated by friction in the rod end housing is the main limitation on sliding velocity. When selecting the rod end size, it is necessary to determine the sliding velocity and the pv-value, which is a product of the specific bearing load  $p$  (N/mm<sup>2</sup>) and the sliding velocity  $v$  (m/s).

Specific bearing load:

$$p = k \cdot \frac{P}{C}$$

Permissible pv-value = 0,5 N/mm<sup>2</sup> · m/s

Where: P = Specific bearing load (N/mm<sup>2</sup>)  
 C = Basic dynamic load rating (N), see individual product pages  
 k = Specific load factor (N/mm<sup>2</sup>) for tribological pairing  
 k = 50 N/mm<sup>2</sup>

Mean sliding velocity:

$$V_m = 5,82 \cdot 10^{-7} \cdot d_3 \cdot \beta \cdot f$$

Permissible sliding velocity  $v_{max.} = 0,15$  m/s

Where:  $V_m$  = Mean sliding velocity (m/s)  
 $d_3$  = Pivot ball diameter (mm), see individual product pages  
 $\beta$  = Half swivelling angle (degree), for swivelling angle > 180°  
 $\beta = 90^\circ$  to be used  
 f = Frequency of oscillation (rpm)

Nominal service life:

$$G = C_1 \cdot C_2 \cdot C_3 \cdot \frac{3}{d_3 \cdot \beta} \cdot \frac{C}{P} \cdot 10^8$$

$$G_h = C_1 \cdot C_2 \cdot C_3 \cdot \frac{5}{d_3 \cdot \beta \cdot f} \cdot \frac{C}{P} \cdot 10^6$$

Where: G = Nominal service life (number of oscillations or revolutions)  
 $G_h$  = Nominal service life (hours)  
 $C_1$  = Load direction factor, see table on next page  
 $C_2$  = Temperature factor, see previous page  
 $C_3$  = Material factor, see alignment chart on next page

Where:  $C_1$  = Load direction factor  
 $C_1 = 1,0$  = Single load direction

Alternating load direction at  $f < 30$  rpm:  $C_1 = 0,250$

Alternating load direction at  $f > 30$  rpm:  $C_1 = 0,125$

### Alignment:

To find  $C_3$  calculate  $C_2 \cdot \frac{C}{P}$  then using this value on the chart below, read across to  $C_3$

Where:  $C_2$  = Temperature factor  
 $C$  = basic dynamic load rating (N) see individual product pages  
 $P$  = Specific bearing load (N/mm<sup>2</sup>)

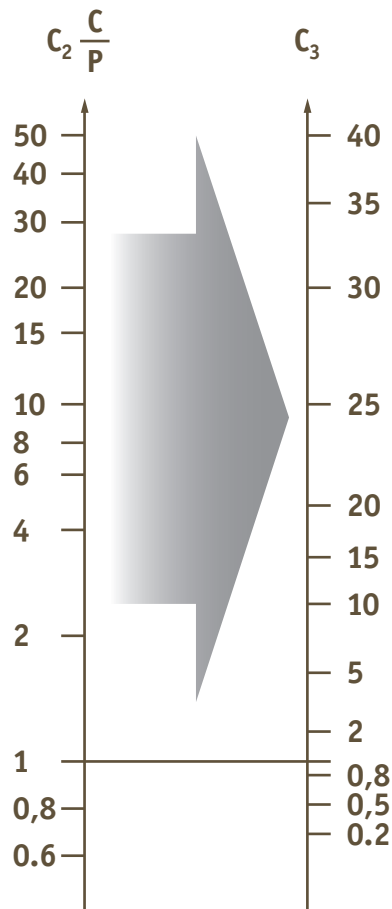

**Calculation example**

The rod end assembly of conveyor equipment calls for heavy-duty rod end with a service life of 7000 hours in conjunction with an alternating acting load of 5 kN. 25 swivelling moments with a swivelling angle of 20° take place per minute. The operating temperature amounts to approx. 60° C. The choice is a heavy-duty rod end R3554.R015 with: C = 13,4 kN, d<sub>3</sub> = 22mm.

Checking the permissible load of the rod end:

$$P_{\max.} = C_0 \cdot C_2 \cdot C_4$$

$$P_{\max.} = 41 \cdot 0,2 \cdot 1,0 = 8,2 \text{ kN} > 5,0 \text{ kN}$$

Where: C<sub>0</sub> = 41 kN  
 C<sub>2</sub> = 1,0 (temperature 60° C)  
 C<sub>4</sub> = 0,2 (alternating load)

Checking the permissible sliding velocity:

$$V_m = 5,82 \cdot 10^{-7} \cdot d_3 \cdot \beta \cdot f = 5,82 \cdot 10^{-7} \cdot 22 \cdot 10 \cdot 25$$

$$= \underline{\underline{0,0032 \text{ m/s} < 0,15 \text{ m/s}}} \quad \checkmark$$

Checking the p · V-value:

$$pV = p \cdot V_m$$

$$pV = 18,66 \cdot 0,0032$$

$$= 0,06 \text{ N/mm}^2 \cdot \text{m/s} < 0,5 \text{ N/mm}^2 \cdot \text{m/s} \quad \checkmark$$

$$p = k \cdot \frac{P}{C} = 50 \cdot \frac{5000}{13400} = 18,66 \text{ N/mm}^2$$

Nominal service life:

$$G_h = C_1 \cdot C_2 \cdot C_3 \cdot \frac{5}{d_3 \cdot \beta \cdot f} \cdot \frac{C}{P} \cdot 10^6$$

$$G_h = 0,25 \cdot 1,0 \cdot 12 \cdot \frac{5}{22 \cdot 10 \cdot 25} \cdot \frac{13,4}{5,0} \cdot 10^6$$

$$= \underline{\underline{7308 \text{ h} > 7000 \text{ h}}} \quad \checkmark$$

Where: C<sub>1</sub> = 0,25 (alternating load direction, f = 25 rpm < 30 rpm)

$$C_3 = C_2 \cdot \frac{C}{P} = 1,0 \cdot \frac{13,4}{5,0} = 2,68$$

See alignment chart (on page 118) C<sub>3</sub> = 12

Where: d<sub>3</sub> = 22  
 f = 25 rpm  
 β = 10° (half the swivelling angle 20° = 10°)  
 C = 13,4 kN  
 P = 5,0 kN

### Low cost rod ends load ratings

The ultimate radial static load rating is measured as the failure point when a load is increasingly applied to a pin through the rod end's bore and pulled straight up while the rod end is held in place. Note that the actual rating is determined by calculating the lowest of the following three values:

1: Raceway material comprehensive strength (R value):

$$R = E \times T \times X$$

2: Rod end head strength (H value, cartridge type construction):

$$H = \left[ \left( \frac{T}{2} \sqrt{D^2 - T^2} \right) + \left( \frac{D^2}{2} \times \text{SIN}^{-1} \frac{T}{2} \right) - (\text{O.D. of Bearing} \times T) \right] \times X$$

Angle of  $\frac{T}{2}$  expressed in radians

3: Shank strength (S Value) male threaded rod end:

$$S = [(\text{root diameter of thread}^2 \times .78) - (N^2 \times .78)] \times X$$

female threaded rod end:

$$S_2 = [(J^2 \times .78) + (\text{major diameter of thread} \times .78)] \times X$$

Where: E = Ball diameter

T = Housing width

X = Allowable stress

D = Head diameter

N = Diameter of drilled hole in shank of male rod end

J = Shank diameter of female rod end

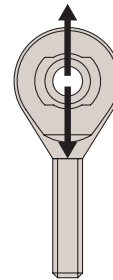

The axial static load capacity is measured as the force required to cause failure via a load parallel to the axis of the bore. Depending on the material types and construction methods, the ultimate axial load is generally 10-20% of the ultimate radial static load. The formula does not account for the bending of the shank due to a moment of force, nor the strength of the stake in cartridge-type construction.

Axial strength (A Value):

$$A = .78 [ (E + .176T)^2 - E^2 ] \times X$$

Where: X = Allowable stress (see table below)

E = Ball diameter

T = Housing width

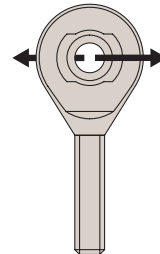

Material	Allowable stress (PSI)
300 Series Stainless Steel	35,000
Low Carbon Steel	52,000



**Operating temperatures**

Heavy-duty ball and roller bearing rod ends can be used for operating temperatures between -20°C and +120°C. The temperature range of heavy-duty rod ends with integral spherical plain bearing is between -30°C and +60°C, without affecting the load capacity. Higher temperatures will reduce the load capacity taken into account for the calculation of the 'working life' under the temperature factor  $C_2$  on page 116.

**Loads**

The decisive parameters for the selection and calculation of heavy-duty rod ends are size, direction and type of load.

**Radial or combined loads**

The heavy-duty rod ends have been especially designed to cope with high radial loads. They can be used for combined loads, the axial load share of which does not exceed 20% of the corresponding radial load.

**Unilaterally acting load**

In this case the load acts only in the same direction, which means that the load area is always in the same bearing section.

**Alternately acting load**

In case of alternating loads, the load areas facing each other are alternately loaded and/or relieved, which means that the load changes its direction constantly by approximately 180°.

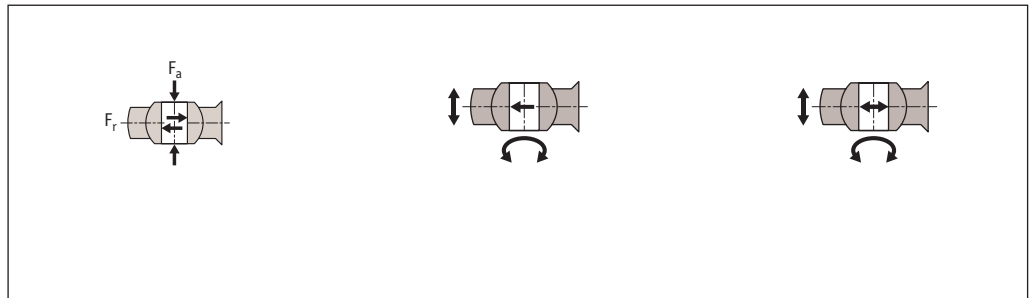

**Swivelling angle**

The swivelling angle is the movement of the rod end from one final position to the other. Half the swivelling angle  $\alpha^\circ$  is used to calculate the service or 'working life'.

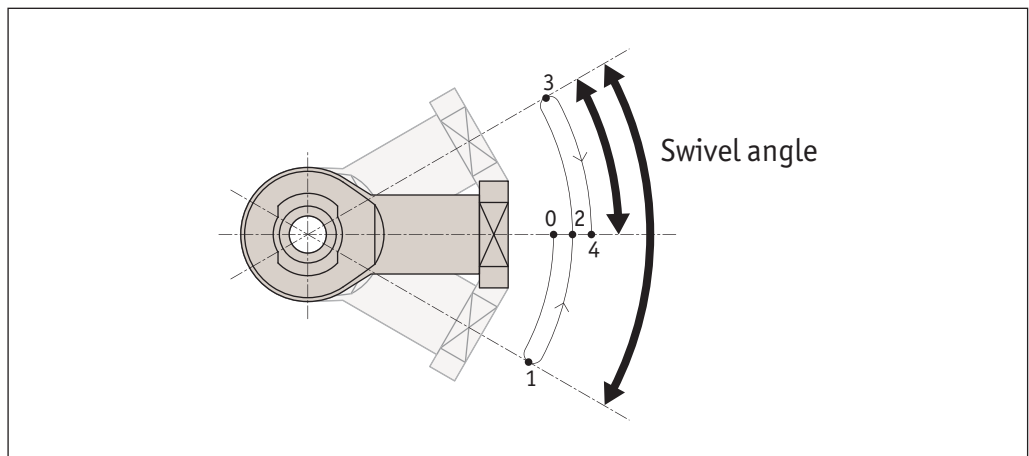



### Angle of tilt

The angle of tilt, also called setting angle, refers to the movement of the joint ball and/or the inner ring to the rod end axis (in degrees). The tilting angle (a) indicated in the table for the heavy-duty ball and roller bearing rod ends corresponds to the maximum possible movement being limited by the shields on both sides. It is important that this tilting angle is not exceeded either during installation or operation, as otherwise the shields may be damaged. For heavy-duty plain bearing rod ends a distinction is made between the tilting angles (a1 and a2).

If the movement is not limited by adjacent components, then angle a1 can fully be used without affecting the rod end capacity. Tilting angle a2 is the movement limit when connecting a forked component.

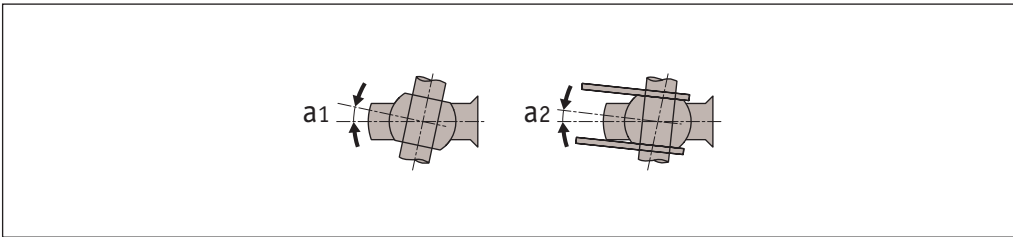

### Nominal service life

The term 'nominal service life' is used for heavy-duty ball and roller bearing rod ends and represents the number of swivelling motions or rotations and/or the number of service hours the rod end performs before showing the first signs of material fatigue on the raceway or roller bodies. In view of many factors that are difficult or impossible to assess, the service life of several apparently identical bearings differ under the same operating conditions.

For this reason, the following method for the service life determination of heavy-duty ball and roller rod ends results in a nominal service life being achieved or exceeded by at least 90% of a large quantity of identical rod ends.

### Working life

The term 'working life' is used with heavy-duty plain bearing rod ends. It represents the number of swivelling motions or rotations and/ or the number of service hours the heavy duty plain bearing rod end performs before becoming unserviceable due to material fatigue, wear, increased bearing clearance or increase of the bearing friction moment.

The 'working life' is not only influenced by the size and the type of load, it is also affected by a number of factors, which are difficult to assess. A calculation of the exact service life is therefore impossible. Field-experienced standard values for the approximate 'working life' can nevertheless be determined by using the following calculation procedure which is based on numerous results from endurance test runs and values from decades of experience. The values determined by this formula are achieved, if not exceeded, by the majority of the heavy-duty rod ends.



Heavy-duty rod ends (R3550, R3551, R3556, R3557, R3561, R3562, R3563, R3564, R3565, R3566, R3610, R3611, R3613, R3614)

d1		d1mp Tolerance Limit		V <sub>d1p</sub>	V <sub>d1mp</sub>	b1s Tolerance Limit		hs, h1s, h2s Tolerance Limit	
over	icl.	upper	lower	max.	max.	upper	lower	upper	lower
	6	+0,012	0	0,012	0,009	0	-0,12	+0,8	-1,2
6	10	+0,015	0	0,015	0,011	0	-0,12	+0,8	-1,2
10	18	+0,018	0	0,018	0,014	0	-0,12	+1,0	-1,7
18	30	+0,021	0	0,021	0,016	0	-0,12	+1,4	-2,1
30	50	+0,025	0	0,025	0,019	0	-0,12	+1,8	-2,7

Heavy-duty rod ends (R3553, R3554, R3559, R3560, R3567, R3568)

d1		d1mp Tolerance Limit		V <sub>d1p</sub>	V <sub>d1mp</sub>	b1s Tolerance Limit		hs, h1s, h2s Tolerance Limit	
over	icl.	upper	lower	max.	max.	upper	lower	upper	lower
	10	0	-0,008	0,008	0,006	0	-0,12	+0,8	-1,2
10	18	0	-0,008	0,008	0,006	0	-0,12	+0,8	-1,2
18	30	0	-0,010	0,010	0,008	0	-0,12	+1,0	-1,7
30	50	0	-0,012	0,012	0,009	0	-0,12	+1,4	-2,1
50	80	0	-0,015	0,015	0,011	0	-0,15	+1,8	-2,7

Dimensions and tolerance symbols

- d<sub>1</sub> = nominal bore diameter of the inner ring or joint ball.
- d<sub>1mp</sub> = mean bore diameter deviation in one plane, arithmetical mean of the largest and smallest bore diameter.
- V<sub>d1p</sub> = bore diameter variation in one plane, difference between the largest and smallest bore diameter.
- V<sub>d1mp</sub> = mean bore diameter variation, difference between the largest and smallest bore diameter of one inner ring or joint ball.
- b<sub>1s</sub> = single inner ring or joint ball width deviation.
- h, h<sub>1</sub>, h<sub>2</sub> = single length from inner ring or ball bore centre to shank end.
- h<sub>s</sub>, h<sub>1s</sub>, h<sub>s2</sub> = single length variation of a single rod end.

Rod Ends from Automation Components

ROD ENDS