

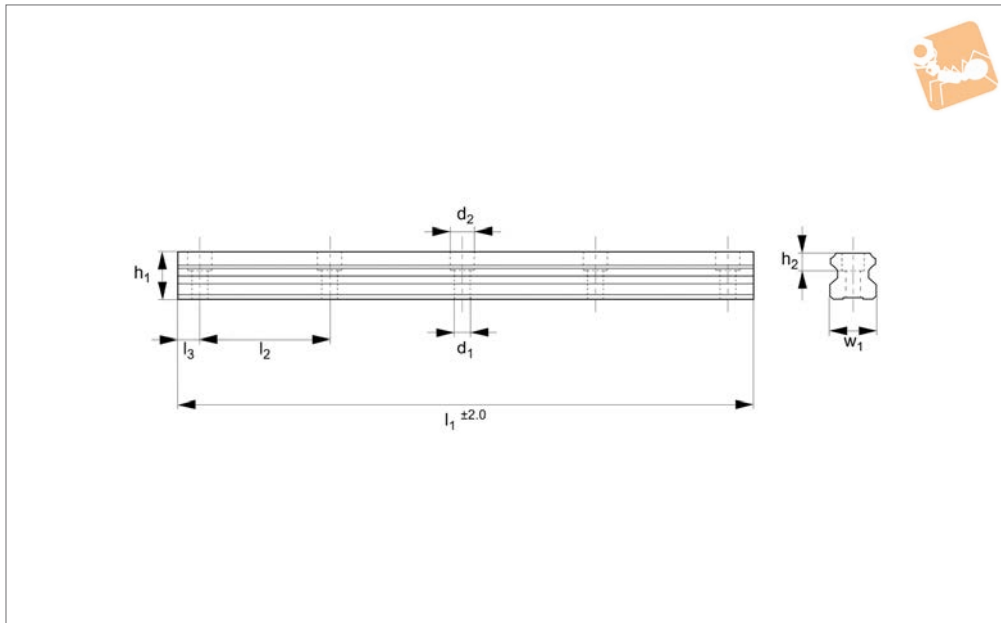

# 20mm Linear Guide Rail

standard

Linear Guide-ways



**L1016.20**

LINEAR GUIDEWAYS

**Material**

Hardened and ground steel (typically 60 HRC).

part nos. L1016.F (flanged) and L1016.U (unflanged).

Other rail lengths on request.  
Weight: 2,6 Kg/m.

**Tips**

Plastic screw covers issued with the rails to protect the holes from debris.

**Technical Notes**

For carriages to suit the required load see

Order No.	Rail size	$l_1$	$h_1$	$l_2$	$w_1$	$l_3$	$h_2$	$d_1$	$d_2$	For screws	Weight kg
L1016.20-0160	20	160	16.3	60	20	20	8.5	6	9.5	M5	0.42
L1016.20-0220	20	220	16.3	60	20	20	8.5	6	9.5	M5	0.57
L1016.20-0280	20	280	16.3	60	20	20	8.5	6	9.5	M5	0.73
L1016.20-0340	20	340	16.3	60	20	20	8.5	6	9.5	M5	0.88
L1016.20-0400	20	400	16.3	60	20	20	8.5	6	9.5	M5	1.04
L1016.20-0460	20	460	16.3	60	20	20	8.5	6	9.5	M5	1.20
L1016.20-0520	20	520	16.3	60	20	20	8.5	6	9.5	M5	1.35
L1016.20-0580	20	580	16.3	60	20	20	8.5	6	9.5	M5	1.51
L1016.20-0640	20	640	16.3	60	20	20	8.5	6	9.5	M5	1.66
L1016.20-0700	20	700	16.3	60	20	20	8.5	6	9.5	M5	1.82
L1016.20-0760	20	760	16.3	60	20	20	8.5	6	9.5	M5	1.98
L1016.20-0820	20	820	16.3	60	20	20	8.5	6	9.5	M5	2.13
L1016.20-0880	20	880	16.3	60	20	20	8.5	6	9.5	M5	2.29
L1016.20-0940	20	940	16.3	60	20	20	8.5	6	9.5	M5	2.44
L1016.20-1000	20	1000	16.3	60	20	20	8.5	6	9.5	M5	2.60
L1016.20-1060	20	1060	16.3	60	20	20	8.5	6	9.5	M5	2.76
L1016.20-1120	20	1120	16.3	60	20	20	8.5	6	9.5	M5	2.91
L1016.20-1180	20	1180	16.3	60	20	20	8.5	6	9.5	M5	3.07
L1016.20-1240	20	1240	16.3	60	20	20	8.5	6	9.5	M5	3.22
L1016.20-1300	20	1300	16.3	60	20	20	8.5	6	9.5	M5	3.38
L1016.20-1360	20	1360	16.3	60	20	20	8.5	6	9.5	M5	3.54
L1016.20-1420	20	1420	16.3	60	20	20	8.5	6	9.5	M5	3.69
L1016.20-1480	20	1480	16.3	60	20	20	8.5	6	9.5	M5	3.85
L1016.20-1540	20	1540	16.3	60	20	20	8.5	6	9.5	M5	4.00
L1016.20-1600	20	1600	16.3	60	20	20	8.5	6	9.5	M5	4.16
L1016.20-1660	20	1660	16.3	60	20	20	8.5	6	9.5	M5	4.32
L1016.20-1720	20	1720	16.3	60	20	20	8.5	6	9.5	M5	4.47
L1016.20-1780	20	1780	16.3	60	20	20	8.5	6	9.5	M5	4.63
L1016.20-1840	20	1840	16.3	60	20	20	8.5	6	9.5	M5	4.78
L1016.20-1900	20	1900	16.3	60	20	20	8.5	6	9.5	M5	4.94
L1016.20-1960	20	1960	16.3	60	20	20	8.5	6	9.5	M5	5.10
L1016.20-2020	20	2020	16.3	60	20	20	8.5	6	9.5	M5	5.25



Order No.	Rail size	l <sub>1</sub>	h <sub>1</sub>	l <sub>2</sub>	w <sub>1</sub>	l <sub>3</sub>	h <sub>2</sub>	d <sub>1</sub>	d <sub>2</sub>	For screws	Weight kg
L1016.20-2080	20	2080	16.3	60	20	20	8.5	6	9.5	M5	5.41
L1016.20-2140	20	2140	16.3	60	20	20	8.5	6	9.5	M5	5.56
L1016.20-2200	20	2200	16.3	60	20	20	8.5	6	9.5	M5	5.72
L1016.20-2260	20	2260	16.3	60	20	20	8.5	6	9.5	M5	5.88
L1016.20-2320	20	2320	16.3	60	20	20	8.5	6	9.5	M5	6.03
L1016.20-2380	20	2380	16.3	60	20	20	8.5	6	9.5	M5	6.19
L1016.20-2440	20	2440	16.3	60	20	20	8.5	6	9.5	M5	6.34
L1016.20-2500	20	2500	16.3	60	20	20	8.5	6	9.5	M5	6.50
L1016.20-2560	20	2560	16.3	60	20	20	8.5	6	9.5	M5	6.66
L1016.20-2620	20	2620	16.3	60	20	20	8.5	6	9.5	M5	6.81
L1016.20-2680	20	2680	16.3	60	20	20	8.5	6	9.5	M5	6.97
L1016.20-2740	20	2740	16.3	60	20	20	8.5	6	9.5	M5	7.12
L1016.20-2800	20	2800	16.3	60	20	20	8.5	6	9.5	M5	7.28
L1016.20-2860	20	2860	16.3	60	20	20	8.5	6	9.5	M5	7.44
L1016.20-2920	20	2920	16.3	60	20	20	8.5	6	9.5	M5	7.59
L1016.20-2980	20	2980	16.3	60	20	20	8.5	6	9.5	M5	7.75
L1016.20-3040	20	3040	16.3	60	20	20	8.5	6	9.5	M5	7.90
L1016.20-3100	20	3100	16.3	60	20	20	8.5	6	9.5	M5	8.06
L1016.20-3160	20	3160	16.3	60	20	20	8.5	6	9.5	M5	8.22
L1016.20-3220	20	3220	16.3	60	20	20	8.5	6	9.5	M5	8.37
L1016.20-3280	20	3280	16.3	60	20	20	8.5	6	9.5	M5	8.53
L1016.20-3340	20	3340	16.3	60	20	20	8.5	6	9.5	M5	8.68
L1016.20-3400	20	3400	16.3	60	20	20	8.5	6	9.5	M5	8.84
L1016.20-3460	20	3460	16.3	60	20	20	8.5	6	9.5	M5	9.00
L1016.20-3520	20	3520	16.3	60	20	20	8.5	6	9.5	M5	9.15
L1016.20-3580	20	3580	16.3	60	20	20	8.5	6	9.5	M5	9.31
L1016.20-3640	20	3640	16.3	60	20	20	8.5	6	9.5	M5	9.46
L1016.20-3700	20	3700	16.3	60	20	20	8.5	6	9.5	M5	9.62
L1016.20-3760	20	3760	16.3	60	20	20	8.5	6	9.5	M5	9.78
L1016.20-3820	20	3820	16.3	60	20	20	8.5	6	9.5	M5	9.93
L1016.20-3880	20	3880	16.3	60	20	20	8.5	6	9.5	M5	10.09
L1016.20-3940	20	3940	16.3	60	20	20	8.5	6	9.5	M5	10.24
L1016.20-4000	20	4000	16.3	60	20	20	8.5	6	9.5	M5	10.40



### L1016 Linear guideways

Linear guideways are widely used throughout industry for heavy-duty and precise applications.

### Precision high load rails

The use of steel balls and the design of the carriages and guideways mean that the rails can accept very heavy loads and significant moment loads. Our rails have circular as opposed to friction coefficient, lower driving resistance, lower wear and lower energy consumption.

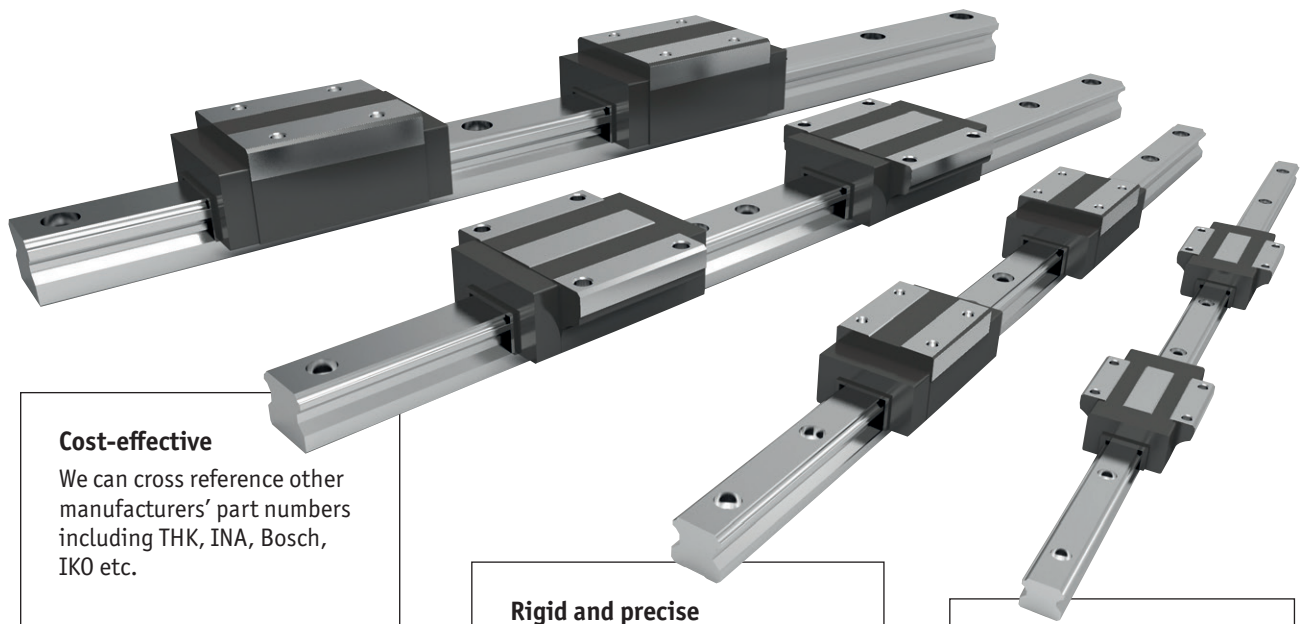

#### Cost-effective

We can cross reference other manufacturers' part numbers including THK, INA, Bosch, IKO etc.

#### Rigid and precise

- High load rating.
- High moment load capacity.

#### Stocked

7 rail profiles ready for same day despatch. Lengths up to 4 metres.

### Rail sizes

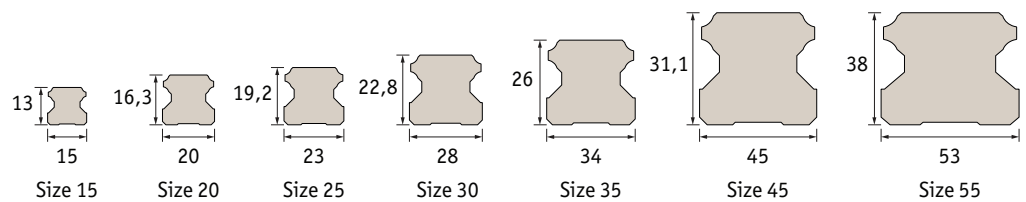

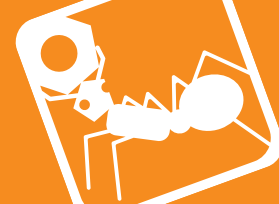

- Carriage types

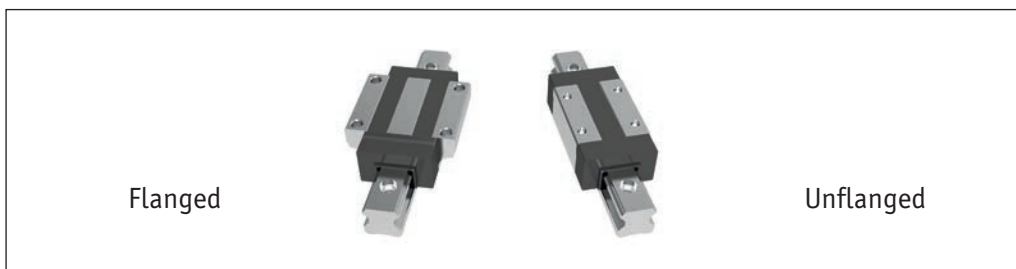

Carriage lengths

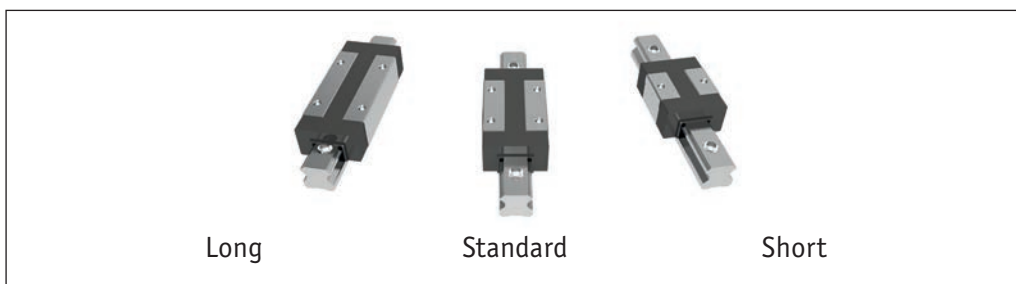

Rail types

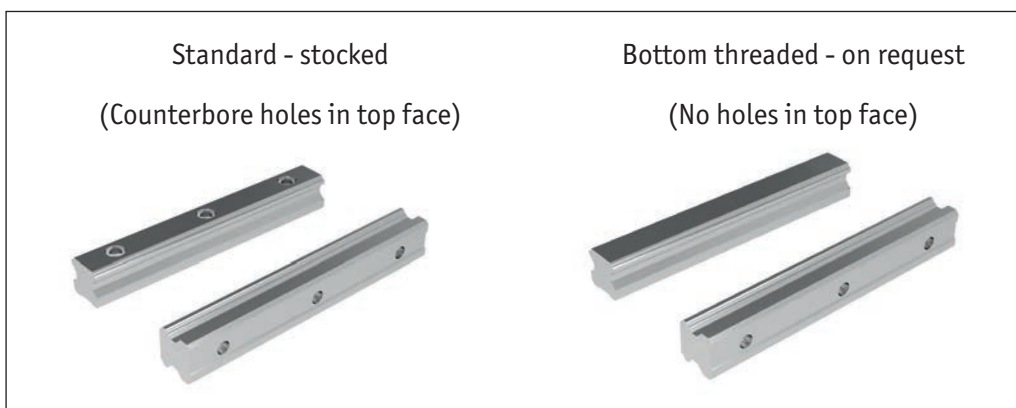

Linear Guideways from Automation Components

### CAD - Download in 3 easy steps

Most of our products are available to download directly from our website. Get the CAD you need for your application in minutes, no registration required.

<p><b>Step 1: find the part you need</b></p> <p>Find the part or enter the Automation part number into the search bar.</p>	
<p><b>Step 2: Choose the CAD option</b></p> <p>Click on the CAD button below the product window to the right of the drawing.</p>	
<p><b>Step 3: Download your format</b></p> <p>Choose the the format you require, and download it to your computer.</p>	

### Load capacities – explained

- A number of load figures are stated for load capacity:

**Dynamic Load** – this is the main figure considered for linear guideways. It is the moving load that the system can bear. It takes account of the total moving load as well as considerations such as impact, vibration and fatigue.

**Static Load** – this is a load that is constant for an extended time (i.e. the dead load the system can bear before any movement). It can be in tension or compression.

For these linear guideways the radial and axial load capacities are the same.

Moment loads are twisting loads generated by offset loads in either X, Y or Z planes. Moment loads can be reduced by adding further carriages or rails to reduce any twisting of the carriage due to the load offset.

### Straightness of rails

- The measurements of the straightness of the system are taken from the running accuracy of the sliders over the length of the rails (given in microns) – see system precision page.
- For standard accuracy this equates to around 20 microns for a metre length, increasing to 35 microns for a 4 metre length.

### What lengths can be provided?

- We have standard rail lengths. These are based on the hole pitch of the rails and end machining to provide an equidistant length to the first and last hole centre.
- However we can cut the rail (from stock) to any length required – we just need to know the distance required to the first hole.
- In general our cutting procedures allow for a  $\pm 2$ mm accuracy on the overall rail length. If greater accuracy than this is required then we have to machine the end accurately (rather than cut it) and this involves extra time and cost.
- Standard maximum length for each rail size is around 4 metres. Rails can be joined together but the preparation needs to be made in our workshop. The rails will be marked clearly with the ends to be placed adjacent to each other.

### Installation

- The linear guideways are very accurate and as a result need to be installed on accurately prepared surfaces – please see installation instructions. If the two rails are installed parallel to each other, they need to be accurately aligned – see assembly precision page.
- If you are not able to prepare the surface as accurately as required you might want to consider using our Compact Rail system, as this has a master rail (T rail) and a slave rail (U rail) that allows for structural inaccuracies.

### Mounting the carriages to the rails

- In general the carriages will be supplied separately to the rails. To install the carriage onto the rails, offer the carriage up to the rails and slide it onto the rail itself.

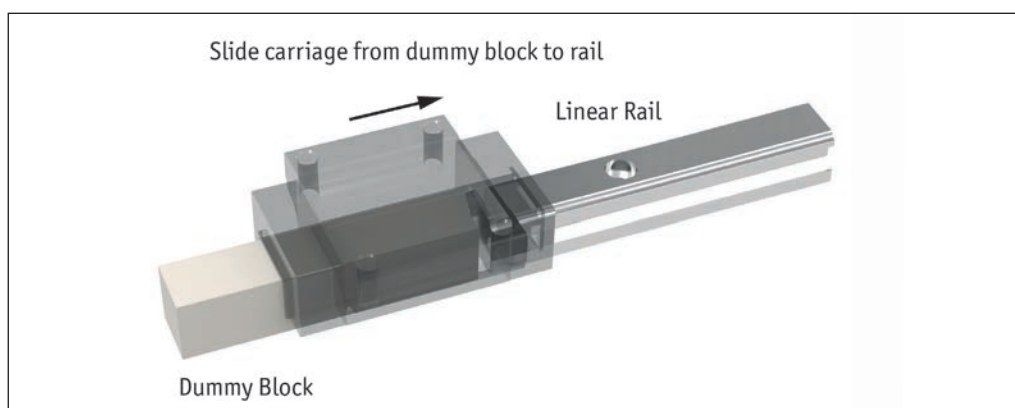



**New ball chain technology**

Our new and improved linear guideway systems include the latest “ball chain” technology with the following benefits:

- Higher maximum velocity.
- Lower heat generation
- Lower noise generation.
- Very smooth running.
- Optimised lubrication system
- Even load distribution
- Longer service life

Linear Guideways from Automation Components

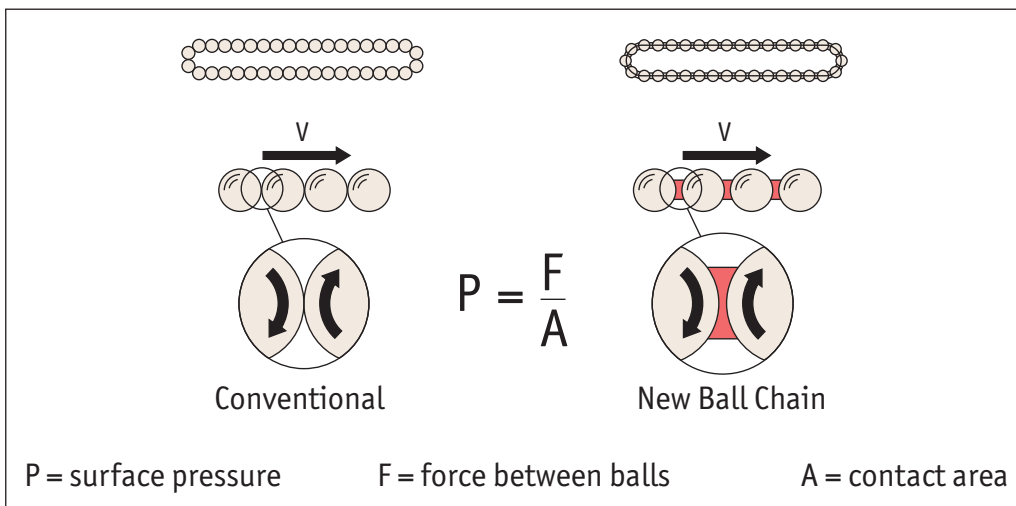

The rotating balls in conventional profile rail guides have point contact between each other. The rotation speed at the contact point is double the speed of the balls. The contact area (A) is so small that the surface pressure (P) tends towards infinity. This leads to heating and wear of the balls and the linear guide system.

The chain system in our new linear guides have a relatively large contact area (A), this significantly reduces the surface area pressure (P). The rotation speeds at the contact surfaces of ball and chain are the same. The ball chain is used to transport the lubricant and to create a lubrication film on the balls. The design of the carriage allows effective supply of lubricant from the lubricant connection to the circulation areas of the ball chains.

This design of the of the ball chain ends in connection with the spacer ball closes the circulation and makes the movement of the carriage smooth and quiet.

