

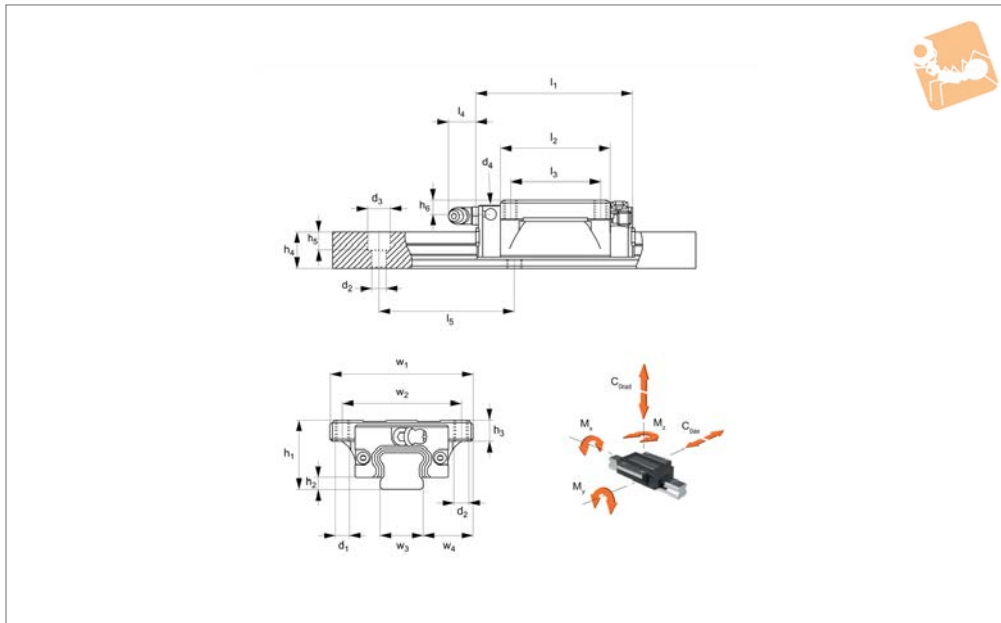

# Flanged Carriages - Standard blackened

## Linear Guide- ways



### L1016.F-BC

LINEAR GUIDEWAYS

#### Material

Hardened and ground steel. Matt black oxide ceramic layer, Thickness 2-10  $\mu$ . No deformation of the parts. Resistant to acids, alkalis and solvents. Relatively soft layer (up to 350 HV), which clears away by rolling over in the area of the raceways. Suitable for applications in the optic and

medical industry.

#### Technical Notes

Select the size and number of carriages to suit the required load then select the required rail length, (see part nos. L1016.15 through to L1016.55). Standard preload carriages are  $K_0$  (no

preload) or  $K_1$  (0,02 x dynamic load capacity). Other preloads available on request.

#### Tips

Improved version with ball cages allowing the carriages to be removed from the rail without the balls falling out.

Order No.	Rail size	$l_1$	$h_1$	$l_2$	$w_1$	$l_3$	$h_2$	$h_3$	$h_4$	$d_1$	$h_5$	$d_2$	$h_6$	$w_2$	$w_3$	$w_4$	$l_4$	Weight kg
L1016.F15-BC	15	58.6	24	40.2	47	30	3.3	8.0	13.0	M 5	6.0	4.5	5.5	38	15	16.0	5.0	0.21
L1016.F15-L-BC	15	66.1	24	47.7	47	30	3.3	8.0	13.0	M 5	6.0	4.5	5.5	38	15	16.0	5.0	0.23
L1016.F20-BC	20	69.3	30	48.5	63	40	4.5	9.0	16.3	M 6	8.5	6.0	7.1	53	20	21.5	15.6	0.40
L1016.F20-L-BC	20	82.1	30	61.3	63	40	4.5	9.0	16.3	M 6	8.5	6.0	7.1	53	20	21.5	15.6	0.46
L1016.F25-BC	25	79.2	36	57.5	70	45	5.8	10.0	19.2	M 8	9.0	7.0	10.2	57	23	23.5	15.6	0.57
L1016.F25-L-BC	25	93.9	36	72.2	70	45	5.8	10.0	19.2	M 8	9.0	7.0	10.2	57	23	23.5	15.6	0.72

Order No.	$l_5$	$d_3$	$d_4$	$M_x$ Nm	$M_y$ Nm	$M_z$ Nm	Dyn. load $C_{rad \& ax}$ kN	Static load $C_{0rad \& ax}$ kN
L1016.F15-BC	60	7.5	M3 x 0,5	137	120	120	11.67	19.90
L1016.F15-L-BC	60	7.5	M3 x 0,5	166	171	171	14.12	24.05
L1016.F20-BC	60	9.5	M6 x 1,0	289	224	224	17.98	30.96
L1016.F20-L-BC	60	9.5	M6 x 1,0	376	366	366	23.30	40.11
L1016.F25-BC	60	11.0	M6 x 1,0	447	358	358	25.25	41.73
L1016.F25-L-BC	60	11.0	M6 x 1,0	576	577	577	32.44	53.63