

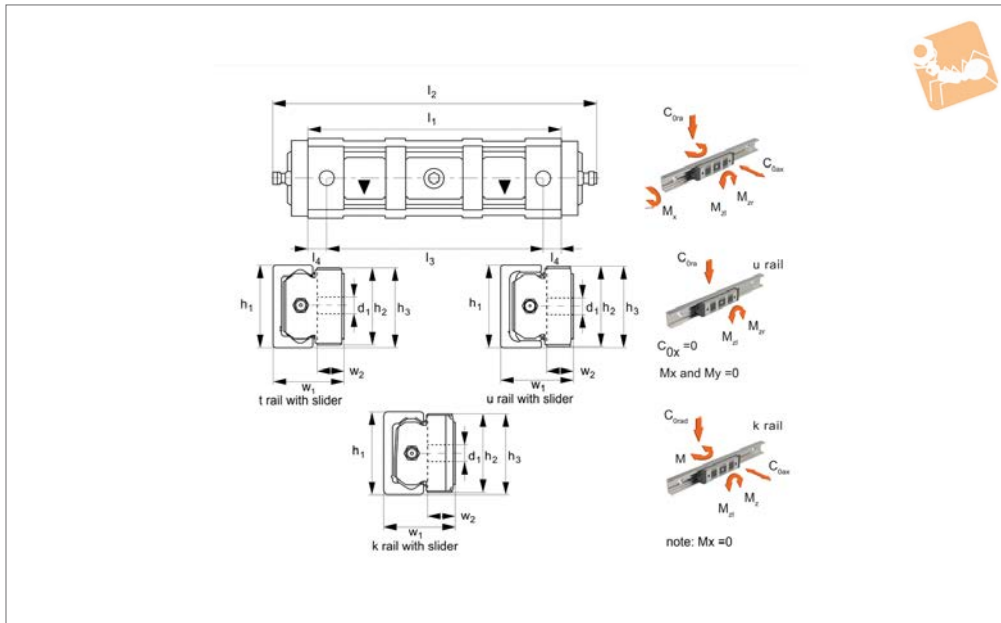

# Heavy Duty Sliders, size 43 standard



Long Linear  
Rails



**L1943.N**

LONG LINEAR RAILS

### Material

Die cast aluminium body, chemically nickel plated.  
Steel rollers (100Cr6) with metal seals (2Z).  
Polyester end pieces and nitrilic rubber side seals.

### Technical Notes

To be used with compact rail size 43.  
Select the relevant sliders to suit the rail size and the required load to be carried (taking into account any moment loads).  
Maintenance free, self-lubricating wipers.

### Tips

Easy to install (the middle bearing is eccentric allowing for adjustable preload).  
Quiet and fast (up to 7 m/s).

Order No.	For rail type	No. of rollers	C N	C <sub>0ax</sub> N	C <sub>0rad</sub> N	d <sub>1</sub>	h <sub>1</sub> +0.35 -0.10	h <sub>2</sub> +0 -0.3	h <sub>3</sub> +0.20 -0.30	l <sub>1</sub>	l <sub>2</sub>	l <sub>3</sub>	Weight kg
L1943.NTE43	T	3	12280	1570	5500	M8	43	40	41.9	134	170	114	0.385
L1943.NUE43	U	3	12280	0	5500	M8	43	40	41.9	134	170	114	0.385
L1943.NKE43	K	3	12280	1320	5100	M8	43	40	41.9	134	170	114	0.385

Order No.	l <sub>4</sub>	M <sub>x</sub> Nm	M <sub>y</sub> Nm	M <sub>z</sub> Nm	w <sub>1</sub> +0.25 -0.10	w <sub>2</sub>
L1943.NTE43	10	23.6	60	104.5	37	13.7
L1943.NUE43	10	0	0	104.5	37	13.7
L1943.NKE43	10	0	50.4	96.9	37	13.7