

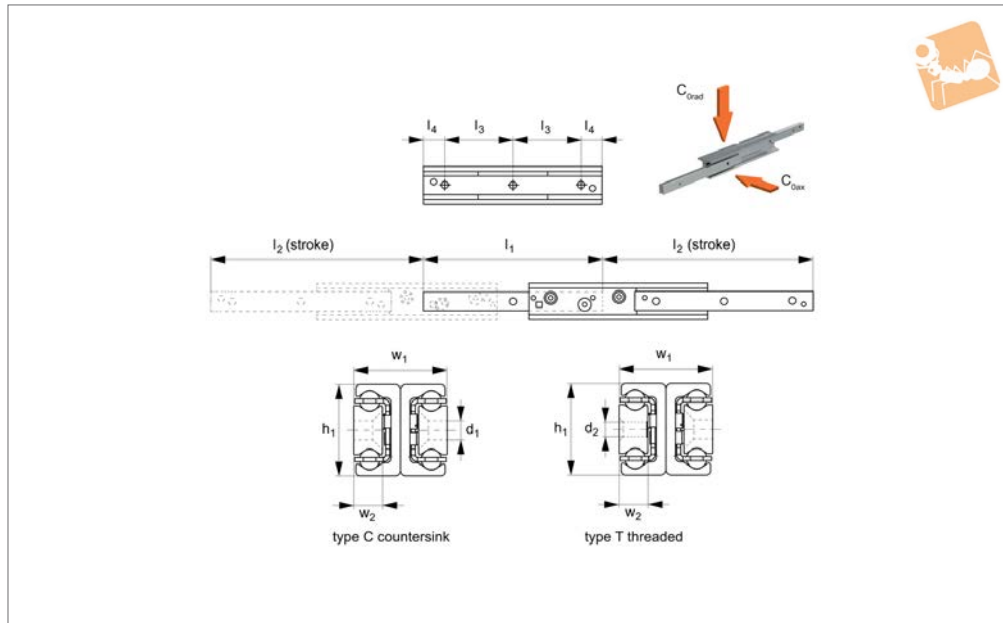

# Fully Telescopic Slides

size 35

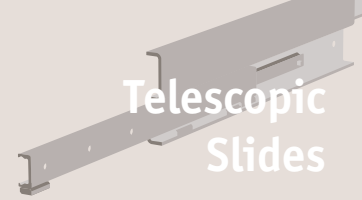

## L1986.35

TELESCOPIC SLIDES

### Material

Cold drawn bearing steel raceways hardened to 60 HRC. Balls - hardened steel.

Zinc coating to ISO2081 (excluding raceways). Corrosion resistant coatings available on request.

### Technical Notes

These are extremely strong and rigid telescopic slides with high load capacities.  $C_{0rad}$

is the load rating for a single telescopic slide.

Temperature range: -30°C to +170°C.

### Tips

A double direction stroke can be obtained by removing the end stops screws at the end of each side of the intermediate member.

For double direction strokes, when the moving element has started the stroke in

the opposite direction it will catch the intermediate member and force it to return.

The slides have end stops, but these are not designed to stop a moving, loaded slide. External end stops should be used for this.

Only to be used for horizontal movements. Special strokes up to 130% of the closed length can be provided on request.

Order No.	$h_1$	$l_1$	$l_2$ stroke	$l_3$	$l_4$	$w_1$	$w_2$	For screws $d_1$ & $d_2$	No. of holes	Hole type	Load (per rail) $N$ max.	$C_{0ax}$	Load (per rail) $N$ max.	$C_{0rad}$	Weight kg
L1986.35C-0210	35	210	254	80	25	33	10	6,5	3	C'sunk	281		402		1,28
L1986.35C-0290	35	290	318	80	25	33	10	6,5	4	C'sunk	560		800		1,76
L1986.35C-0370	35	370	406	80	25	33	10	6,5	5	C'sunk	718		1025		2,25
L1986.35C-0450	35	450	494	80	25	33	10	6,5	6	C'sunk	793		1250		2,74
L1986.35C-0530	35	530	558	80	25	33	10	6,5	7	C'sunk	728		1685		3,23
L1986.35C-0610	35	610	646	80	25	33	10	6,5	8	C'sunk	626		1908		3,72
L1986.35C-0690	35	690	734	80	25	33	10	6,5	9	C'sunk	548		1689		4,20
L1986.35C-0770	35	770	798	80	25	33	10	6,5	10	C'sunk	516		1591		4,69
L1986.35C-0850	35	850	886	80	25	33	10	6,5	11	C'sunk	463		1425		5,18
L1986.35C-0930	35	930	974	80	25	33	10	6,5	12	C'sunk	419		1291		5,67
L1986.35C-1010	35	1010	1038	80	25	33	10	6,5	13	C'sunk	400		1233		6,16
L1986.35C-1090	35	1090	1126	80	25	33	10	6,5	14	C'sunk	367		1131		6,64
L1986.35C-1170	35	1170	1214	80	25	33	10	6,5	15	C'sunk	339		1045		7,13
L1986.35C-1250	35	1250	1278	80	25	33	10	6,5	16	C'sunk	327		1006		7,62
L1986.35C-1330	35	1330	1366	80	25	33	10	6,5	17	C'sunk	308		937		8,11
L1986.35C-1410	35	1410	1454	80	25	33	10	6,5	18	C'sunk	285		877		8,60
L1986.35C-1490	35	1490	1518	80	25	33	10	6,5	19	C'sunk	276		850		9,08
L1986.35T-0210	35	210	254	80	25	33	10	6,5	3	Thread	281		402		1,28
L1986.35T-0290	35	290	318	80	25	33	10	6,5	4	Thread	560		800		1,76
L1986.35T-0370	35	370	406	80	25	33	10	6,5	5	Thread	718		1025		2,25
L1986.35T-0450	35	450	494	80	25	33	10	6,5	6	Thread	793		1250		2,74
L1986.35T-0530	35	530	558	80	25	33	10	6,5	7	Thread	728		1685		3,23
L1986.35T-0610	35	610	646	80	25	33	10	6,5	8	Thread	626		1908		3,72
L1986.35T-0690	35	690	734	80	25	33	10	6,5	9	Thread	548		1689		4,20
L1986.35T-0770	35	770	798	80	25	33	10	6,5	10	Thread	516		1591		4,69



Order No.	$h_1$	$l_1$	$l_2$ stroke	$l_3$	$l_4$	$w_1$	$w_2$	For screws $d_1$ & $d_2$	No. of holes	Hole type	Load (per rail) $C_{0\text{ ax}}$ N max.	Load (per rail) $C_{0\text{ rad}}$ N max.	Weight kg
<b>L1986.35T-0850</b>	35	850	886	80	25	33	10	6,5	11	Thread	463	1425	5,18
<b>L1986.35T-0930</b>	35	930	974	80	25	33	10	6,5	12	Thread	419	1291	5,67
<b>L1986.35T-1010</b>	35	1010	1038	80	25	33	10	6,5	13	Thread	400	1233	6,16
<b>L1986.35T-1090</b>	35	1090	1126	80	25	33	10	6,5	14	Thread	367	1131	6,64
<b>L1986.35T-1170</b>	35	1170	1214	80	25	33	10	6,5	15	Thread	339	1045	7,13
<b>L1986.35T-1250</b>	35	1250	1278	80	25	33	10	6,5	16	Thread	327	1006	7,62
<b>L1986.35T-1330</b>	35	1330	1366	80	25	33	10	6,5	17	Thread	308	937	8,11
<b>L1986.35T-1410</b>	35	1410	1454	80	25	33	10	6,5	18	Thread	285	877	8,60
<b>L1986.35T-1490</b>	35	1490	1518	80	25	33	10	6,5	19	Thread	276	850	9,08

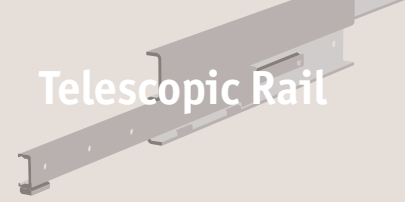

If you are looking for heavy duty, quality telescopic rails for industrial or commercial applications then these are the rails for you!

### The best heavy duty telescopic slides on the market

These are unique rails that are not made from pressed steel but from cold-drawn steel section. The rails can take high loads, with very long strokes, with repeated use, low deflection and minimal play.

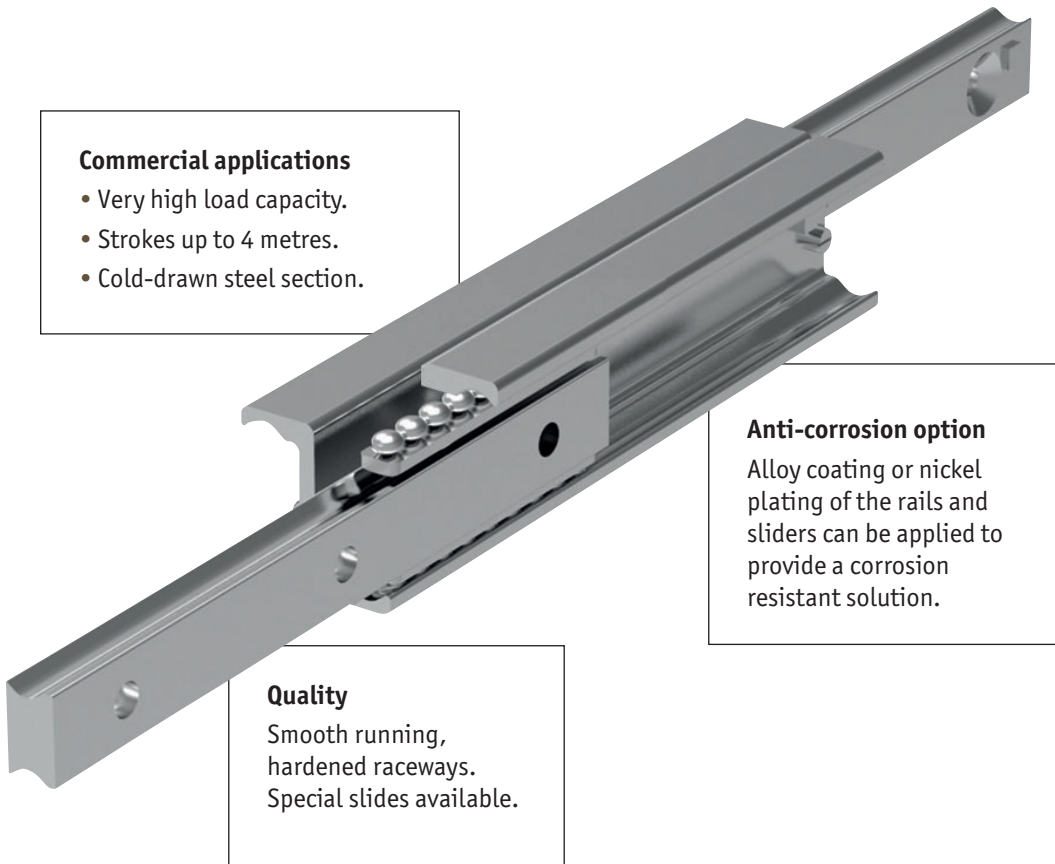

**Commercial applications**

- Very high load capacity.
- Strokes up to 4 metres.
- Cold-drawn steel section.

**Anti-corrosion option**  
Alloy coating or nickel plating of the rails and sliders can be applied to provide a corrosion resistant solution.

**Quality**  
Smooth running, hardened raceways. Special slides available.



Partial Stroke (~60%)

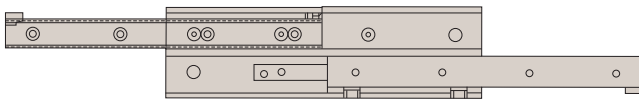

Full Stroke (~100%)

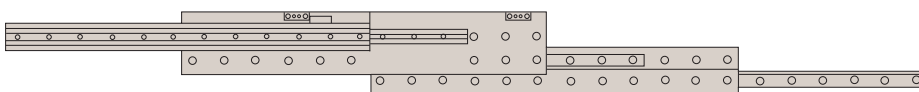

Over-extension (150%)

### Rail types

Our range of telescopic rails covers partial, full stroke and over-extension.

For more information refer to our product specifications pages or call our technical department.



### Specifications

- Generally all our telescopic rails have induction hardened raceways.
- Cold drawn roller bearing steel.
- Maximum operating speed 0,8 m/s.
- Temperature range (mainly -30°C to +170°C).
- Electrolytic galvanised to ISO 2081, other anti-corrosion finishes on request.
- High load ratings with low deflection characteristics.
- Minimum play (even at maximum load ratings).
- Smooth, free running movement.
- Long strokes and heavy load ratings.
- Can be used in horizontal applications only (due to the use of a ball cage), with the exception of part number L1985 which uses roller bearings.
- Light duty “cage stops” are included on the telescopic rails to prevent damage to the ball cage. External end stops must be designed into your application (to protect the rails from high forces and possible damage on opening and closing).
- For telescopic rails with an “upper” and “lower” rail, the moving rail should be the lower one. Using the upper rail as the moving element effects the smooth running and the load capacity of the telescopic sliders.
- All load capacity figures are given for a single rail, and based on continuous use.
- Fix to structures using screws of strength class 10,9.
- Anti-corrosion option. We have a highly effective anti-corrosive coating option, and we utilise stainless steel ball bearings in this version.

### Applications



#### Special purpose & packaging machines

Precision positioning systems  
handling units  
robotic systems • cutting machines



#### Seating

Sliding seats  
disability ramps  
seat extensions



#### Safety guarding

Extending protective systems  
sliding gates  
automatic pick & place



#### Logistics solutions

Container extensions  
heavy duty extending systems  
sliding doors



#### Disability vehicles

Sliding seats  
extension ramps



#### Transport (naval)

Sliding hatches  
pull-out storage



#### Transport (rail)

Seat adjustment  
sliding doors  
battery removal units



#### Transport (automotive)

Ambulance sliding systems  
fire fighting vehicles  
sliding panels



#### Transport (military)

Sliding seats  
protective hatches  
stretcher extensions

**L1989** - these are full extension slides made from 316L stainless steel. For use in applications where corrosion may be a problem.

Standard extension	100%
Special extension range	No
Single & double direction?	No
Number of rail sizes	1
Maximum extension (at 100%)	1120 mm
Maximum load (per rail)	35 Kg



### Extended stroke telescopic rails

**L1997** - these are extended stroke (150%), heavy duty telescopic rails, with high load capacity and stiffness.

Standard extension	150%
Special extension range	On request
Single & double direction?	No
Number of rail sizes	1
Maximum extension (at 150%)	3030 mm
Maximum load (per rail)	240 Kg



**L1998** - these are extended stroke (150%), heavy duty telescopic rails. They have a solid steel intermediate element. They are our heaviest duty extended stroke units.

Standard extension	150%
Special extension range	On request
Single & double direction?	No
Number of rail sizes	1
Maximum extension (at 150%)	3020 mm
Maximum load (per rail)	480 Kg

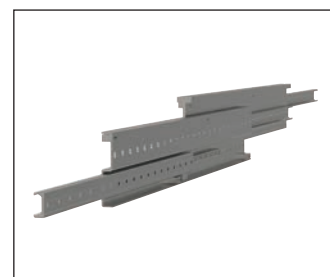



### Service life

The service life is defined as the time span between commissioning and the first fatigue or wear indications on the raceway. The service life of a telescopic rail is dependent on several factors, such as the effective load, the installation precision, occurring shocks and vibrations, the operating temperature, the ambient conditions and the lubrication.

Calculation of the service life is based exclusively on the loaded rows of balls.

In practice, the decommissioning of the bearing, due to its destruction or extreme wear of a component, represents the end of service life.

This is taken into account by an application coefficient ( $f_i$ ), so the service life consists of:

$$L_{Km} = 100 \cdot \left( \frac{\delta}{W} \cdot \frac{1}{f_i} \right)^3$$

$L$  = calculated service life in Km

$\delta$  = load capacity factor in N (see tables on following pages)

$W$  = equivalent load in N

$f_i$  = application coefficient

### Application coefficient $f_i$

Operating conditions	Safety factor ( $f_i$ )
Neither shocks or vibrations, smooth and low-frequency direction change, clean environment	1,3 - 1,8
Light vibrations and average direction change	1,8 - 2,3
Shocks and vibrations, high-frequency direction change, very dirty environment	2,3 - 3,5

If the external load,  $P$ , is the same as the dynamic load capacity,  $C_{0rad}$  (which of course must never be exceeded), the service life at ideal operating conditions ( $f_i = 1$ ) is 100Km.

For a single load  $P$ , the following applies:  $W = P$ .

If several external loads occur simultaneously, the equivalent load is calculated as follows:

$$W = P_{rad} + \left( \frac{P_{ax}}{C_{0ax}} + \frac{M_1}{M_x} + \frac{M_2}{M_y} + \frac{M_3}{M_z} \right) \cdot C_{0rad}$$