

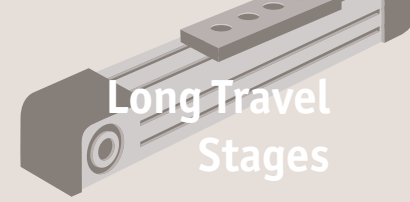

Medium Duty Belt Driven Unit

size 55



Long Travel Stages

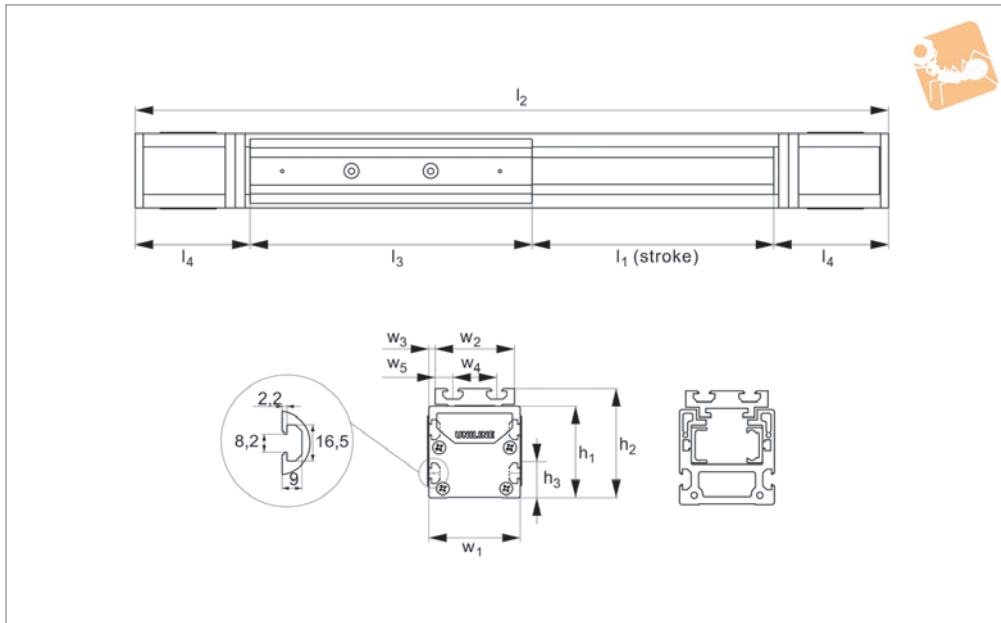

L3003.C55

LONG TRAVEL STAGES

Material

Special sliders on a pair of hardened steel rails, encased in an aluminium profile.

Technical Notes

Any length overall stroke unit can be supplied (up to 1,9 metres in a single section) for the C55 series. Longer strokes

available.

Longer carriages and double carriages are available which increase the load capacity of the units.

Tips

See technical pages for more information on belt specification, long carriages,

double carriages and motor connections. Can easily be combined to make an XY, XYZ or other set up gantry system.

Important Notes

For loads with significant M_y moment loads.

Order No.	l_1	l_2	h_3	l_3	h_1 & w_1	h_2	l_4	w_2	w_3	w_4	w_5	C_{0ax} N	C_{0rad} N	M_x Nm	M_y Nm	M_z Nm
L3003.C55-0100	100	516	15	200	55	71	108	52	1.5	28	12	1640	300	18.5	65.6	11.7
L3003.C55-0200	200	616	15	200	55	71	108	52	1.5	28	12	1640	300	18.5	65.6	11.7
L3003.C55-0300	300	716	15	200	55	71	108	52	1.5	28	12	1640	300	18.5	65.6	11.7
L3003.C55-0400	400	816	15	200	55	71	108	52	1.5	28	12	1640	300	18.5	65.6	11.7
L3003.C55-0500	500	916	15	200	55	71	108	52	1.5	28	12	1640	300	18.5	65.6	11.7
L3003.C55-0600	600	1016	15	200	55	71	108	52	1.5	28	12	1640	300	18.5	65.6	11.7
L3003.C55-0700	700	1116	15	200	55	71	108	52	1.5	28	12	1640	300	18.5	65.6	11.7
L3003.C55-0800	800	1216	15	200	55	71	108	52	1.5	28	12	1640	300	18.5	65.6	11.7
L3003.C55-0900	900	1316	15	200	55	71	108	52	1.5	28	12	1640	300	18.5	65.6	11.7
L3003.C55-1000	1000	1416	15	200	55	71	108	52	1.5	28	12	1640	300	18.5	65.6	11.7
L3003.C55-1100	1100	1516	15	200	55	71	108	52	1.5	28	12	1640	300	18.5	65.6	11.7
L3003.C55-1200	1200	1616	15	200	55	71	108	52	1.5	28	12	1640	300	18.5	65.6	11.7
L3003.C55-1300	1300	1716	15	200	55	71	108	52	1.5	28	12	1640	300	18.5	65.6	11.7
L3003.C55-1400	1400	1816	15	200	55	71	108	52	1.5	28	12	1640	300	18.5	65.6	11.7
L3003.C55-1500	1500	1916	15	200	55	71	108	52	1.5	28	12	1640	300	18.5	65.6	11.7
L3003.C55-1600	1600	2016	15	200	55	71	108	52	1.5	28	12	1640	300	18.5	65.6	11.7
L3003.C55-1700	1700	2116	15	200	55	71	108	52	1.5	28	12	1640	300	18.5	65.6	11.7
L3003.C55-1800	1800	2216	15	200	55	71	108	52	1.5	28	12	1640	300	18.5	65.6	11.7