

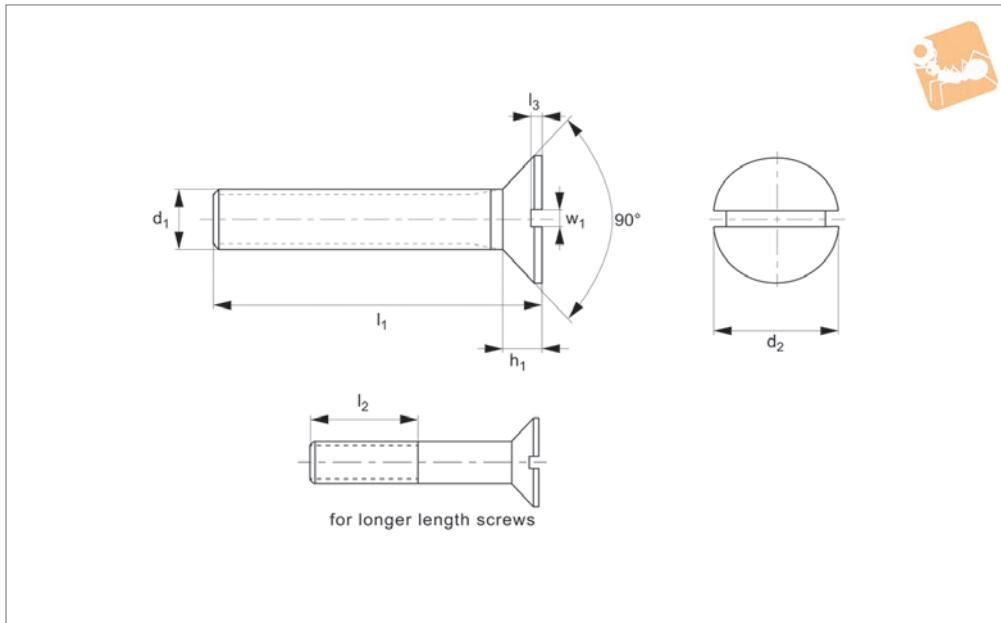

Slot Countersunk Machine Screws

Slot - steel, zinc-plated

Standard Screws



P0224.ZP

STANDARD SCREWS

Material

Steel, zinc-plated (grade 4.8).

Technical Notes

To DIN 963, ISO 2009. For the majority of

screw lengths the threads goes all the way to the head of the screw (i.e. $l_2 = l_1$) less 2.5 thread pitches.

For longer length screws the threaded

portion $l_2 < l_1$.

Order No.	d_1	l_1	d_2	l_2	l_3	h_1	w_1
P0224.016-003-ZP	M1,6	3	3	-	0.32	0.96	0.4
P0224.016-004-ZP	M1,6	4	3	-	0.32	0.96	0.4
P0224.016-005-ZP	M1,6	5	3	-	0.32	0.96	0.4
P0224.016-006-ZP	M1,6	6	3	-	0.32	0.96	0.4
P0224.016-008-ZP	M1,6	8	3	-	0.32	0.96	0.4
P0224.016-010-ZP	M1,6	10	3	-	0.32	0.96	0.4
P0224.016-012-ZP	M1,6	12	3	-	0.32	0.96	0.4
P0224.016-014-ZP	M1,6	14	3	-	0.32	0.96	0.4
P0224.016-016-ZP	M1,6	16	3	-	0.32	0.96	0.4
P0224.020-004-ZP	M 2	4	3.8	-	0.40	1.20	0.5
P0224.020-005-ZP	M 2	5	3.8	-	0.40	1.20	0.5
P0224.020-006-ZP	M 2	6	3.8	-	0.40	1.20	0.5
P0224.020-008-ZP	M 2	8	3.8	-	0.40	1.20	0.5
P0224.020-010-ZP	M 2	10	3.8	-	0.40	1.20	0.5
P0224.020-012-ZP	M 2	12	3.8	-	0.40	1.20	0.5
P0224.020-014-ZP	M 2	14	3.8	-	0.40	1.20	0.5
P0224.020-016-ZP	M 2	16	3.8	16	0.40	1.20	0.5
P0224.020-018-ZP	M 2	18	3.8	16	0.40	1.20	0.5
P0224.020-020-ZP	M 2	20	3.8	16	0.40	1.20	0.5
P0224.020-022-ZP	M 2	22	3.8	16	0.40	1.20	0.5
P0224.020-025-ZP	M 2	25	3.8	16	0.40	1.20	0.5
P0224.020-030-ZP	M 2	30	3.8	16	0.40	1.20	0.5
P0224.025-004-ZP	M2,5	4	4.7	-	0.50	1.50	0.6
P0224.025-005-ZP	M2,5	5	4.7	-	0.50	1.50	0.6
P0224.025-006-ZP	M2,5	5	4.7	-	0.50	1.50	0.6
P0224.025-008-ZP	M2,5	8	4.7	-	0.50	1.50	0.6
P0224.025-010-ZP	M2,5	10	4.7	-	0.50	1.50	0.6
P0224.025-012-ZP	M2,5	12	4.7	-	0.50	1.50	0.6
P0224.025-014-ZP	M2,5	14	4.7	-	0.50	1.50	0.6
P0224.025-016-ZP	M2,5	16	4.7	-	0.50	1.50	0.6
P0224.025-018-ZP	M2,5	18	4.7	18	0.50	1.50	0.6
P0224.025-020-ZP	M2,5	20	4.7	18	0.50	1.50	0.6
P0224.025-022-ZP	M2,5	22	4.7	18	0.50	1.50	0.6
P0224.025-025-ZP	M2,5	25	4.7	18	0.50	1.50	0.6



STANDARD SCREWS

Order No.	d ₁	l ₁	d ₂	l ₂	l ₃	h ₁	w ₁
P0224.025-030-ZP	M2,5	30	4.7	18	0.50	1.50	0.6
P0224.030-004-ZP	M 3	4	5.6	-	0.60	1.65	0.8
P0224.030-005-ZP	M 3	5	5.6	-	0.60	1.65	0.8
P0224.030-006-ZP	M 3	6	5.6	-	0.60	1.65	0.8
P0224.030-008-ZP	M 3	8	5.6	-	0.60	1.65	0.8
P0224.030-010-ZP	M 3	10	5.6	-	0.60	1.65	0.8
P0224.030-012-ZP	M 3	12	5.6	-	0.60	1.65	0.8
P0224.030-014-ZP	M 3	14	5.6	-	0.60	1.65	0.8
P0224.030-016-ZP	M 3	16	5.6	-	0.60	1.65	0.8
P0224.030-018-ZP	M 3	18	5.6	-	0.60	1.65	0.8
P0224.030-020-ZP	M 3	20	5.6	19	0.60	1.65	0.8
P0224.030-022-ZP	M 3	22	5.6	19	0.60	1.65	0.8
P0224.030-025-ZP	M 3	25	5.6	19	0.60	1.65	0.8
P0224.030-030-ZP	M 3	30	5.6	19	0.60	1.65	0.8
P0224.030-035-ZP	M 3	35	5.6	19	0.60	1.65	0.8
P0224.030-040-ZP	M 3	40	5.6	19	0.60	1.65	0.8
P0224.030-045-ZP	M 3	45	5.6	19	0.60	1.65	0.8
P0224.030-050-ZP	M 3	50	5.6	19	0.60	1.65	0.8
P0224.030-055-ZP	M 3	55	5.6	19	0.60	1.65	0.8
P0224.030-060-ZP	M 3	60	5.6	19	0.60	1.65	0.8
P0224.035-005-ZP	M3,5	5	6.5	-	0.70	1.93	0.8
P0224.035-006-ZP	M3,5	6	6.5	-	0.70	1.93	0.8
P0224.035-008-ZP	M3,5	8	6.5	-	0.70	1.93	0.8
P0224.035-010-ZP	M3,5	10	6.5	-	0.70	1.93	0.8
P0224.035-012-ZP	M3,5	12	6.5	-	0.70	1.93	0.8
P0224.035-014-ZP	M3,5	14	6.5	-	0.70	1.93	0.8
P0224.035-016-ZP	M3,5	16	6.5	-	0.70	1.93	0.8
P0224.035-018-ZP	M3,5	18	6.5	-	0.70	1.93	0.8
P0224.035-020-ZP	M3,5	20	6.5	20	0.70	1.93	0.8
P0224.035-022-ZP	M3,5	22	6.5	20	0.70	1.93	0.8
P0224.035-025-ZP	M3,5	25	6.5	20	0.70	1.93	0.8
P0224.035-030-ZP	M3,5	30	6.5	20	0.70	1.93	0.8
P0224.035-035-ZP	M3,5	35	6.5	20	0.70	1.93	0.8
P0224.040-005-ZP	M 4	5	7.5	-	0.80	2.20	1.0
P0224.040-006-ZP	M 4	6	7.5	-	0.80	2.20	1.0
P0224.040-008-ZP	M 4	8	7.5	-	0.80	2.20	1.0
P0224.040-010-ZP	M 4	10	7.5	-	0.80	2.20	1.0
P0224.040-012-ZP	M 4	12	7.5	-	0.80	2.20	1.0
P0224.040-014-ZP	M 4	14	7.5	-	0.80	2.20	1.0
P0224.040-016-ZP	M 4	16	7.5	-	0.80	2.20	1.0
P0224.040-018-ZP	M 4	18	7.5	-	0.80	2.20	1.0
P0224.040-020-ZP	M 4	20	7.5	-	0.80	2.20	1.0
P0224.040-022-ZP	M 4	22	7.5	22	0.80	2.20	1.0
P0224.040-025-ZP	M 4	25	7.5	22	0.80	2.20	1.0
P0224.040-030-ZP	M 4	30	7.5	22	0.80	2.20	1.0
P0224.040-035-ZP	M 4	35	7.5	22	0.80	2.20	1.0
P0224.040-040-ZP	M 4	40	7.5	22	0.80	2.20	1.0
P0224.040-045-ZP	M 4	45	7.5	22	0.80	2.20	1.0
P0224.040-050-ZP	M 4	50	7.5	22	0.80	2.20	1.0
P0224.040-055-ZP	M 4	55	7.5	22	0.80	2.20	1.0
P0224.040-060-ZP	M 4	60	7.5	22	0.80	2.20	1.0
P0224.040-065-ZP	M 4	65	7.5	22	0.80	2.20	1.0
P0224.040-070-ZP	M 4	70	7.5	22	0.80	2.20	1.0
P0224.040-075-ZP	M 4	75	7.5	22	0.80	2.20	1.0
P0224.040-080-ZP	M 4	80	7.5	22	0.80	2.20	1.0
P0224.050-006-ZP	M 5	6	9.2	-	1.00	2.50	1.2
P0224.050-008-ZP	M 5	8	9.2	-	1.00	2.50	1.2
P0224.050-010-ZP	M 5	10	9.2	-	1.00	2.50	1.2
P0224.050-012-ZP	M 5	12	9.2	-	1.00	2.50	1.2
P0224.050-014-ZP	M 5	14	9.2	-	1.00	2.50	1.2
P0224.050-016-ZP	M 5	16	9.2	-	1.00	2.50	1.2
P0224.050-018-ZP	M 5	18	9.2	-	1.00	2.50	1.2
P0224.050-020-ZP	M 5	20	9.2	-	1.00	2.50	1.2
P0224.050-022-ZP	M 5	22	9.2	-	1.00	2.50	1.2
P0224.050-025-ZP	M 5	25	9.2	25	1.00	2.50	1.2
P0224.050-030-ZP	M 5	30	9.2	25	1.00	2.50	1.2
P0224.050-035-ZP	M 5	35	9.2	25	1.00	2.50	1.2
P0224.050-040-ZP	M 5	40	9.2	25	1.00	2.50	1.2
P0224.050-045-ZP	M 5	45	9.2	25	1.00	2.50	1.2



Slot Countersunk Machine Screws

Slot - steel, zinc-plated

Standard Screws



Order No.	d ₁	l ₁	d ₂	l ₂	l ₃	h ₁	w ₁
P0224.050-050-ZP	M 5	50	9.2	25	1.00	2.50	1.2
P0224.050-055-ZP	M 5	55	9.2	25	1.00	2.50	1.2
P0224.050-060-ZP	M 5	60	9.2	25	1.00	2.50	1.2
P0224.050-065-ZP	M 5	65	9.2	25	1.00	2.50	1.2
P0224.050-070-ZP	M 5	70	9.2	25	1.00	2.50	1.2
P0224.050-075-ZP	M 5	75	9.2	25	1.00	2.50	1.2
P0224.050-080-ZP	M 5	80	9.2	25	1.00	2.50	1.2
P0224.050-090-ZP	M 5	90	9.2	25	1.00	2.50	1.2
P0224.050-100-ZP	M 5	100	9.2	25	1.00	2.50	1.2
P0224.060-008-ZP	M 6	8	11.0	-	1.20	3.00	1.6
P0224.060-010-ZP	M 6	10	11.0	-	1.20	3.00	1.6
P0224.060-012-ZP	M 6	12	11.0	-	1.20	3.00	1.6
P0224.060-014-ZP	M 6	14	11.0	-	1.20	3.00	1.6
P0224.060-016-ZP	M 6	16	11.0	-	1.20	3.00	1.6
P0224.060-018-ZP	M 6	18	11.0	-	1.20	3.00	1.6
P0224.060-020-ZP	M 6	20	11.0	-	1.20	3.00	1.6
P0224.060-022-ZP	M 6	22	11.0	-	1.20	3.00	1.6
P0224.060-025-ZP	M 6	25	11.0	-	1.20	3.00	1.6
P0224.060-030-ZP	M 6	30	11.0	28	1.20	3.00	1.6
P0224.060-035-ZP	M 6	35	11.0	28	1.20	3.00	1.6
P0224.060-040-ZP	M 6	40	11.0	28	1.20	3.00	1.6
P0224.060-045-ZP	M 6	45	11.0	28	1.20	3.00	1.6
P0224.060-050-ZP	M 6	50	11.0	28	1.20	3.00	1.6
P0224.060-055-ZP	M 6	55	11.0	28	1.20	3.00	1.6
P0224.060-060-ZP	M 6	60	11.0	28	1.20	3.00	1.6
P0224.060-065-ZP	M 6	65	11.0	28	1.20	3.00	1.6
P0224.060-070-ZP	M 6	70	11.0	28	1.20	3.00	1.6
P0224.060-075-ZP	M 6	75	11.0	28	1.20	3.00	1.6
P0224.060-080-ZP	M 6	80	11.0	28	1.20	3.00	1.6
P0224.060-090-ZP	M 6	90	11.0	28	1.20	3.00	1.6
P0224.060-100-ZP	M 6	100	11.0	28	1.20	3.00	1.6
P0224.060-110-ZP	M 6	110	11.0	28	1.20	3.00	1.6
P0224.060-120-ZP	M 6	120	11.0	28	1.20	3.00	1.6
P0224.080-010-ZP	M 8	10	14.5	-	1.60	4.00	2.0
P0224.080-012-ZP	M 8	12	14.5	-	1.60	4.00	2.0
P0224.080-014-ZP	M 8	14	14.5	-	1.60	4.00	2.0
P0224.080-016-ZP	M 8	16	14.5	-	1.60	4.00	2.0
P0224.080-018-ZP	M 8	18	14.5	-	1.60	4.00	2.0
P0224.080-020-ZP	M 8	20	14.5	-	1.60	4.00	2.0
P0224.080-022-ZP	M 8	22	14.5	-	1.60	4.00	2.0
P0224.080-025-ZP	M 8	25	14.5	-	1.60	4.00	2.0
P0224.080-030-ZP	M 8	30	14.5	-	1.60	4.00	2.0
P0224.080-035-ZP	M 8	35	14.5	34	1.60	4.00	2.0
P0224.080-040-ZP	M 8	40	14.5	34	1.60	4.00	2.0
P0224.080-045-ZP	M 8	45	14.5	34	1.60	4.00	2.0
P0224.080-050-ZP	M 8	50	14.5	34	1.60	4.00	2.0
P0224.080-055-ZP	M 8	55	14.5	34	1.60	4.00	2.0
P0224.080-060-ZP	M 8	60	14.5	34	1.60	4.00	2.0
P0224.080-065-ZP	M 8	65	14.5	34	1.60	4.00	2.0
P0224.080-070-ZP	M 8	70	14.5	34	1.60	4.00	2.0
P0224.080-075-ZP	M 8	75	14.5	34	1.60	4.00	2.0
P0224.080-080-ZP	M 8	80	14.5	34	1.60	4.00	2.0
P0224.080-090-ZP	M 8	90	14.5	34	1.60	4.00	2.0
P0224.080-100-ZP	M 8	100	14.5	34	1.60	4.00	2.0
P0224.080-110-ZP	M 8	110	14.5	34	1.60	4.00	2.0
P0224.080-120-ZP	M 8	120	14.5	34	1.60	4.00	2.0
P0224.100-016-ZP	M10	16	18.0	-	2.00	5.00	2.5
P0224.100-018-ZP	M10	18	18.0	-	2.00	5.00	2.5
P0224.100-020-ZP	M10	20	18.0	-	2.00	5.00	2.5
P0224.100-022-ZP	M10	22	18.0	-	2.00	5.00	2.5
P0224.100-025-ZP	M10	25	18.0	-	2.00	5.00	2.5
P0224.100-030-ZP	M10	30	18.0	-	2.00	5.00	2.5
P0224.100-035-ZP	M10	35	18.0	-	2.00	5.00	2.5
P0224.100-040-ZP	M10	40	18.0	40	2.00	5.00	2.5
P0224.100-045-ZP	M10	45	18.0	40	2.00	5.00	2.5
P0224.100-050-ZP	M10	50	18.0	40	2.00	5.00	2.5
P0224.100-055-ZP	M10	55	18.0	40	2.00	5.00	2.5
P0224.100-060-ZP	M10	60	18.0	40	2.00	5.00	2.5
P0224.100-065-ZP	M10	65	18.0	40	2.00	5.00	2.5

STANDARD SCREWS



STANDARD SCREWS

Order No.	d ₁	l ₁	d ₂	l ₂	l ₃	h ₁	w ₁
P0224.100-070-ZP	M10	70	18.0	40	2.00	5.00	2.5
P0224.100-075-ZP	M10	75	18.0	40	2.00	5.00	2.5
P0224.100-080-ZP	M10	80	18.0	40	2.00	5.00	2.5
P0224.100-090-ZP	M10	90	18.0	40	2.00	5.00	2.5
P0224.100-100-ZP	M10	100	18.0	40	2.00	5.00	2.5
P0224.100-110-ZP	M10	110	18.0	40	2.00	5.00	2.5
P0224.100-120-ZP	M10	120	18.0	40	2.00	5.00	2.5
P0224.120-020-ZP	M12	20	22.0	-	2.40	6.00	3.0
P0224.120-022-ZP	M12	22	22.0	-	2.40	6.00	3.0
P0224.120-025-ZP	M12	25	22.0	-	2.40	6.00	3.0
P0224.120-030-ZP	M12	30	22.0	-	2.40	6.00	3.0
P0224.120-035-ZP	M12	35	22.0	-	2.40	6.00	3.0
P0224.120-040-ZP	M12	40	22.0	-	2.40	6.00	3.0
P0224.120-045-ZP	M12	45	22.0	46	2.40	6.00	3.0
P0224.120-050-ZP	M12	50	22.0	46	2.40	6.00	3.0
P0224.120-055-ZP	M12	55	22.0	46	2.40	6.00	3.0
P0224.120-060-ZP	M12	60	22.0	46	2.40	6.00	3.0
P0224.120-065-ZP	M12	65	22.0	46	2.40	6.00	3.0
P0224.120-070-ZP	M12	70	22.0	46	2.40	6.00	3.0
P0224.120-075-ZP	M12	75	22.0	46	2.40	6.00	3.0
P0224.120-080-ZP	M12	80	22.0	46	2.40	6.00	3.0
P0224.120-090-ZP	M12	90	22.0	46	2.40	6.00	3.0
P0224.120-100-ZP	M12	100	22.0	46	2.40	6.00	3.0
P0224.120-110-ZP	M12	110	22.0	46	2.40	6.00	3.0
P0224.120-120-ZP	M12	120	22.0	46	2.40	6.00	3.0