

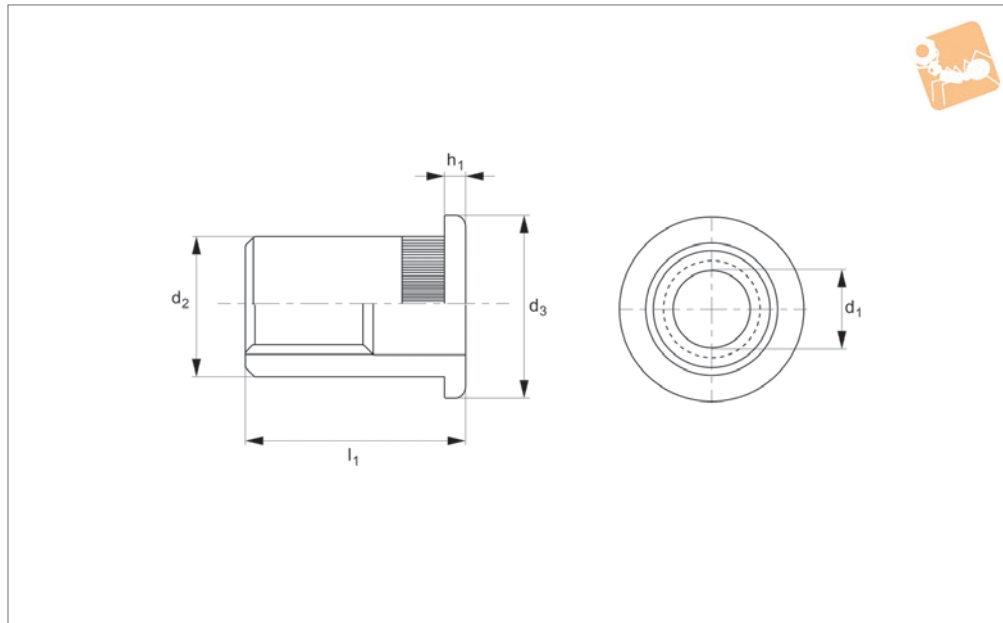

Flange Head Knurled Insert Nuts

Aluminium

Insert Nuts



P0820.AL

INSERT NUTS

Material
Aluminium.

Technical Notes
Knurled body type, plain available on request.

Flange head insert nuts are recommended for use in load bearing applications. The larger sized head acts as a reinforcement to the hole and provides resistance to push-out.

The knurled body provides extra turning resistance and the head acts as a spacer.

Tips
Also known as blind rivet nuts or grip nuts.

Order No.	d ₁	Grip range	d ₂ +0 -0.2	d ₃	h ₁	l ₁
P0820.030-025-AL	M 3	0,5-2,5	4.9	7.0	0.8	10.5
P0820.030-035-AL	M 3	2,5-3,5	4.9	7.0	0.8	11.5
P0820.040-030-AL	M 4	0,5-3,0	5.9	9.0	1.0	11.0
P0820.040-045-AL	M 4	3,0-4,0	5.9	9.0	1.0	14.0
P0820.050-025-AL	M 5	0,5-3,0	6.9	10.0	1.0	13.0
P0820.050-055-AL	M 5	3,0-5,5	6.9	10.0	1.0	16.0
P0820.050-080-AL	M 5	5,5-8,0	6.9	10.0	1.0	19.0
P0820.060-030-AL	M 6	0,5-3,0	8.9	12.0	1.5	16.0
P0820.060-055-AL	M 6	3,0-5,5	8.9	12.0	1.5	18.5
P0820.060-080-AL	M 6	5,5-8,0	8.9	12.0	1.5	21.0
P0820.080-030-AL	M 8	0,5-3,0	10.9	15.0	1.5	17.5
P0820.080-055-AL	M 8	3,0-5,5	10.9	15.0	1.5	20.0
P0820.080-080-AL	M 8	5,5-8,0	10.9	15.0	1.5	22.5
P0820.080-105-AL	M 8	8,0-10,5	10.9	15.0	1.5	25.0
P0820.100-030-AL	M10	0,5-3,0	11.9	16.0	2.0	19.0
P0820.100-060-AL	M10	3,0-6,0	11.9	16.0	2.0	24.0
P0820.100-090-AL	M10	6,0-9,0	11.9	16.0	2.0	27.0
P0820.100-120-AL	M10	9,0-12,0	11.9	16.0	2.0	30.0
P0820.120-040-AL	M12	1,0-4,0	15.9	22.0	2.0	25.0
P0820.120-070-AL	M12	4,0-7,0	15.9	22.0	2.0	28.0
P0820.120-100-AL	M12	7,0-10,0	15.9	22.0	2.0	31.0