

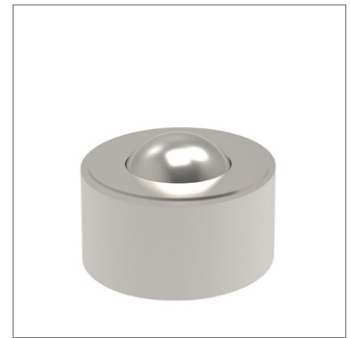

# Plain-Fit Ball Transfer Units

medium duty

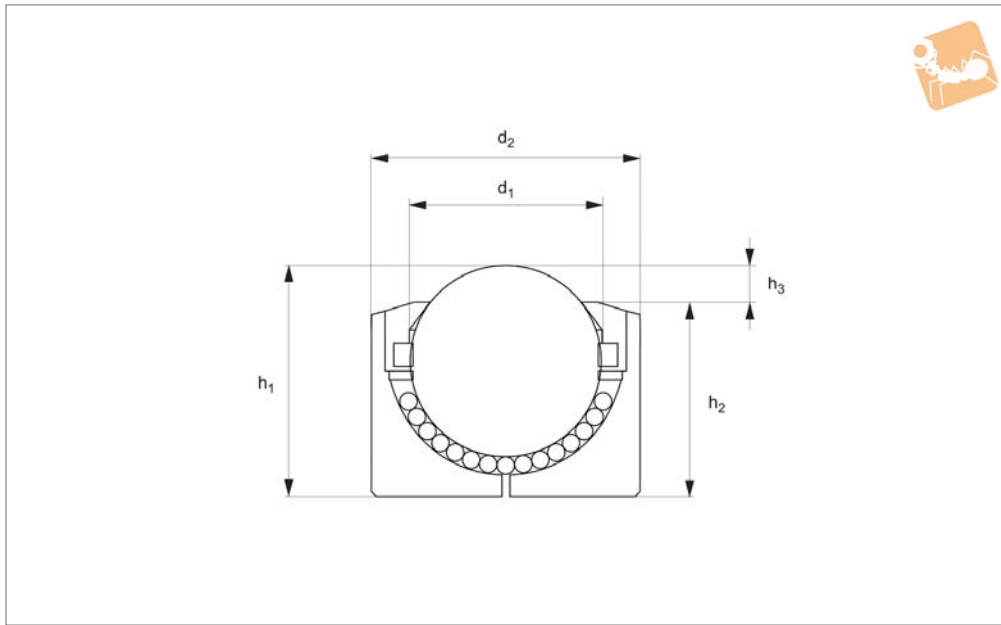

**P2711**

MATERIAL HANDLING

**Material**

Steel (AISI 1040 housing and AISI 52100 for balls), stainless steel (AISI 416 for housing and AISI 420 for balls) and acetal (POM).

**Technical Notes**

These ball transfer units are made of a solid steel block with a precision machined hemispherical carrying bowl.

Top cover plates are shaped to ensure the perfect conveyance of items which have possible burred or bent edges. This design also prevents possible damage to the carrying ball.

Provided with a hole in the base of the bearing cup to dispose of particles of dirt and swarf (this may also be used for re-lubrication purposes).

Manufactured without a flange on the housing, therefore the whole load is being supported only by the bottom face of the unit.

**Tips**

These rollers can only be used in the horizontal or „ball up“ direction.

Order No.	d <sub>1</sub>	d <sub>2</sub>	h <sub>1</sub>	h <sub>2</sub>	h <sub>3</sub>	Housing	Ball	Load kg max.
P2711.080-CC	8	18	12.0	10.0	2.0	Steel	Steel	13
P2711.080-CS	8	18	12.0	10.0	2.0	Steel	Stainless	10
P2711.080-SS	8	18	12.0	10.0	2.0	Stainless	Stainless	8.4
P2711.120-CS	12	20	16.5	13.5	3.0	Steel	Stainless	20
P2711.150-CS	15	24	20.0	15.0	5.0	Steel	Stainless	50
P2711.220-CS	22	36	30.5	27.9	4.5	Steel	Stainless	180
P2711.300-CS	30	45	36.8	30.3	6.5	Steel	Stainless	350
P2711.450-CS	45	62	53.5	45.0	8.5	Steel	Stainless	600
P2711.600-CS	60	100	77.5	61	16.5	Steel	Stainless	1100
P2711.120-CC	12	20	16.5	13.5	3.0	Steel	Steel	25
P2711.120-CA	12	20	16.5	13.5	3.0	Steel	Acetal	5
P2711.120-SS	12	20	16.5	13.5	3.0	Stainless	Stainless	14
P2711.150-CC	15	24	20.0	15.0	5.0	Steel	Steel	60
P2711.150-CA	15	24	20.0	15.0	5.0	Steel	Acetal	10
P2711.150-SS	15	24	20.0	15.0	5.0	Stainless	Stainless	40
P2711.220-CC	22	36	30.5	27.9	4.5	Steel	Steel	180
P2711.220-CA	22	36	30.5	27.9	4.5	Steel	Acetal	20
P2711.220-SS	22	36	30.5	27.9	2.6	Stainless	Stainless	125
P2711.300-CC	30	45	36.8	30.3	6.5	Steel	Steel	350
P2711.300-CA	30	45	36.8	30.3	6.5	Steel	Acetal	25
P2711.300-SS	30	45	36.8	30.3	6.5	Stainless	Stainless	245
P2711.450-CC	45	62	53.5	45.0	8.5	Steel	Steel	600
P2711.450-CA	45	62	53.5	45.0	8.5	Steel	Acetal	25
P2711.450-SS	45	62	53.5	45.0	8.5	Stainless	Stainless	420
P2711.600-CC	60	100	77.5	61	16.5	Steel	Steel	1500



Order No.	d <sub>1</sub>	d <sub>2</sub>	h <sub>1</sub>	h <sub>2</sub>	h <sub>3</sub>	Housing	Ball	Load kg max.
<b>P2711.600-CA</b>	60	100	77.5	61	16.5	Steel	Acetal	35
<b>P2711.600-SS</b>	60	100	77.5	61	16.5	Stainless	Stainless	1000



## Product selection

Housing	Ball	Load Factor	
Steel	Steel	1,0	Housing: AISI 1040 steel, machined, toughened & zinc plated. Ball: AISI 52100 chrome steel
Steel	Stainless	0,7	Housing: AISI 1040 steel, machined, toughened & zinc plated. Ball: AISI 420 stainless steel
Stainless	Stainless	0,7	Housing: AISI 416 stainless steel. Ball: AISI 420 stainless steel
Steel	Acetal		Housing: AISI 1040 steel, machined, toughened & zinc plated. Ball: POM acetal
Aluminium	Stainless		Housing: aluminium. Ball: AISI 420 stainless steel
Acetal	Acetal		Housing: POM acetal. Ball: POM acetal
Acetal	Stainless		Housing: POM acetal. Ball: AISI 420 stainless steel

## Available materials

Part No.	Ball Size	Minimum Bore $\varnothing$	Maximum Bore $\varnothing$
67202.W9015	15	24,8	25,0
67202.W9022	22	37,0	37,2
67202.W9030	30	46,3	46,7

## Fixing clip selection

Clip requires a minimum plate thickness of 3mm to grip securely

Ball Type	Max Load (Kg)	Friction (% of load)	Speed (m/s)	Shock Loads	Arduous Conditions	Orientation	Instant Change
Medium Duty	20-3500	2%	1,5	✓✓✓	✓✓		✓✓✓
Light Duty	7-250	3%	1,0	✓	✓✓		✓✓✓

## How to select the correct unit



## Variables to consider

**Shock Loads:**  
Specify High Capacity series & spring loaded units

**Track Hardness/Conveyed Item Material:**  
Standard material ball units have Rockwell 'C' hardness of 60 minimum

**Delicate Surfaces:**  
Ball Units - Acetal (POM) & Phenolic Resin

**Operating Environment:**  
Wet, dirty, outdoor, radioactive

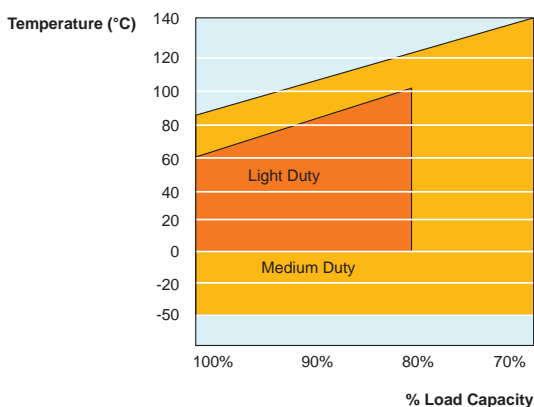

## Operation temperature



## Load and stability

To determine the load of a ball transfer unit, the weight of the article to be conveyed should be divided by 3. If the height tolerance of the load balls is good and the surface of the workpiece to be conveyed is suitable, the calculation can be based on the number of ball transfer units under the load.

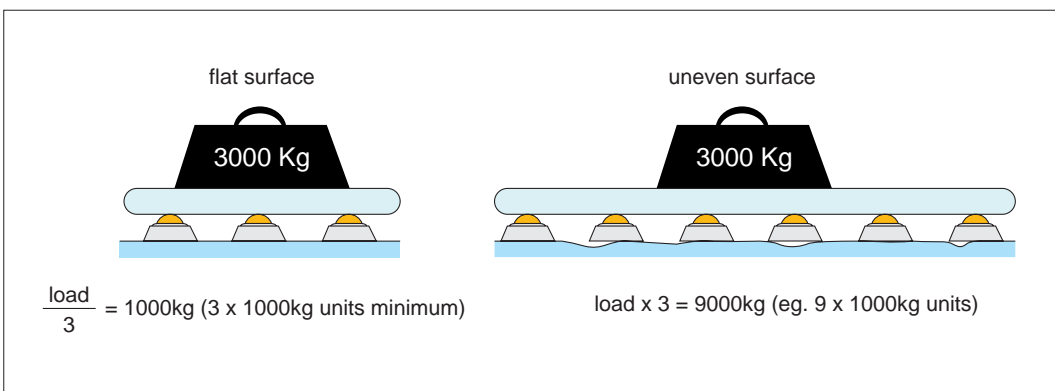

## Pitching and spacing

How the ball transfer units should be arranged depends on the bottom surface of the load to be transported. For loads with a uniform, even bottom surface, e.g. packing cases, the distance between the ball transfer units is calculated by dividing the smallest dimension by 3,5.

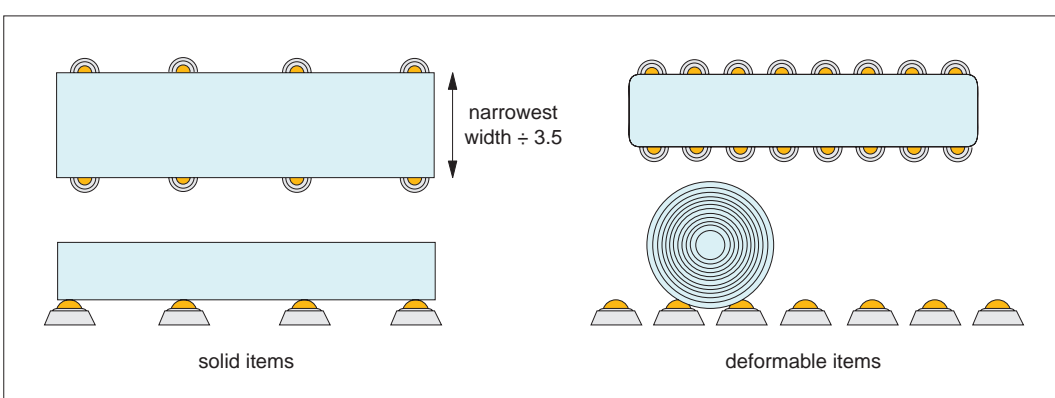

## Conveying speed and load capacity

The maximum conveying speed allowed amounts to 2m/s. The load capacities specified apply to any mounting position and are based on  $10^6$  rotations of the load ball. With the units being used over a longer time at speeds exceeding 1m/s, an increase in temperature as well as a reduction in travel life must be expected depending on the load.

## Calculation of travel life

$$L = \frac{C^3}{F} 10^6 \text{ rotations}$$

L = travel life  
C = load capacity (N)  
F = load (N)

## Friction

The diagram shows the friction values as a function of load and speed for ball transfer units. These approximate values apply to all mounting positions with operation on a hardened steel plate.

v = 1m/s

