

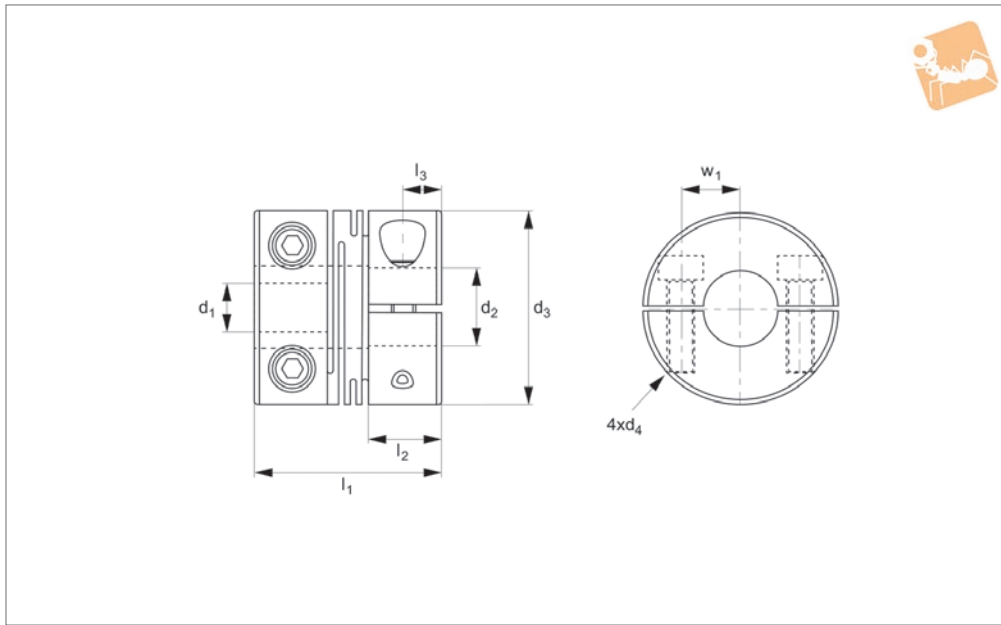

Beamed Coupling - three beam aluminium, set screw type

Flexible Couplings

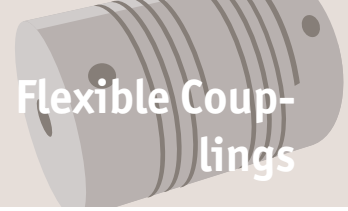

R3006

FLEXIBLE COUPLINGS

Material

Anodized aluminium (DIN 1725), black.

Technical Notes

One piece construction, no mechanical joints.

No backlash.

Constant velocity.

Torsionally rigid.

High flexibility.

Temperature range -40°C to +120°C.

Central relief diameter may be smaller than

bore in some cases.

Max Torque:

Select the size where max.torque exceeds the application target service factor.

Service Factors:

Shock + reversing = 2

Non reversing = 1,5

Steady load = 1

Max. rpm = 5,000

Torsional stiffness:

based on - bore diameter of minimum D_2 for size at load of (max torque/2).

Tips

Suitable for:

encoders, stepper motors, precision ball screws, robotics, scientific equipment, measuring systems, medical systems, pumps, servo systems etc.

Order No.	d ₁	d ₂	d ₃	d ₄	l ₁	l ₂	n	Ang. offset	Par. offset mm	Torque Nm max.	Tors. stiffness Nm/rad	Weight g
R3006.A02-03	1.9	3	9.5	M2,5	14.2	2	4.5	3°	0.100	0.4	2	2
R3006.A02-04	1.9	4	9.5	M2,5	14.2	2	4.5	3°	0.100	0.4	2	2
R3006.A03-03	1.9	3	9.5	M2,5	14.2	3	4.5	3°	0.100	0.4	2	2
R3006.A03-04	1.9	4	9.5	M2,5	14.2	3	4.5	3°	0.100	0.4	2	2
R3006.A04-04	1.9	4	9.5	M2,5	14.2	4	4.5	3°	0.100	0.4	2	2
R3006.B03-04	2.8	4	12.7	M3	19.1	3	6.0	5°	0.127	0.9	36	5
R3006.B03-05	2.8	5	12.7	M3	19.1	3	6.0	5°	0.127	0.9	36	5
R3006.B03-06	2.8	6	12.7	M3	19.1	3	6.0	5°	0.127	0.9	36	5
R3006.B04-04	2.8	4	12.7	M3	19.1	4	6.0	5°	0.127	0.9	36	5
R3006.B04-05	2.8	5	12.7	M3	19.1	4	6.0	5°	0.127	0.9	36	5
R3006.B04-06	2.8	6	12.7	M3	19.1	4	6.0	5°	0.127	0.9	36	5
R3006.B05-05	2.8	5	12.7	M3	19.1	5	6.0	5°	0.127	0.9	36	5
R3006.B05-06	2.8	6	12.7	M3	19.1	5	6.0	5°	0.127	0.9	36	5
R3006.B06-06	2.8	6	12.7	M3	19.1	6	6.0	5°	0.127	0.9	36	5
R3006.C03-04	2.8	4	15.9	M4	20.3	3	6.5	5°	0.127	1.5	63	8
R3006.C03-05	2.8	5	15.9	M4	20.3	3	6.5	5°	0.127	1.5	63	8
R3006.C03-06	2.8	6	15.9	M4	20.3	3	6.5	5°	0.127	1.5	63	8
R3006.C03-08	2.8	8	15.9	M4	20.3	3	6.5	5°	0.127	1.5	63	8
R3006.C04-05	2.8	5	15.9	M4	20.3	4	6.5	5°	0.127	1.5	63	8
R3006.C04-06	2.8	6	15.9	M4	20.3	4	6.5	5°	0.127	1.5	63	8
R3006.C04-08	2.8	8	15.9	M4	20.3	4	6.5	5°	0.127	1.5	63	8
R3006.C05-05	2.8	5	15.9	M4	20.3	5	6.5	5°	0.127	1.5	63	8
R3006.C05-06	2.8	6	15.9	M4	20.3	5	6.5	5°	0.127	1.5	63	8
R3006.C05-08	2.8	8	15.9	M4	20.3	5	6.5	5°	0.127	1.5	63	8



Order No.	d ₁	d ₂	d ₃	d ₄	l ₁	l ₂	n	Ang. offset	Par. offset mm	Torque Nm max.	Tors. stiffness Nm/rad	Weight g
R3006.C06-06	2.8	6	15.9	M4	20.3	6	6.5	5°	0.127	1.5	63	8
R3006.C06-08	2.8	8	15.9	M4	20.3	6	6.5	5°	0.127	1.5	63	8
R3006.C08-08	2.8	8	15.9	M4	20.3	8	6.5	5°	0.127	1.5	63	8
R3006.D03-05	2.8	5	19.1	M4	22.9	3	6.5	5°	0.127	2.5	50	15
R3006.D03-06	2.8	6	19.1	M4	22.9	3	6.5	5°	0.127	2.5	50	15
R3006.D03-08	2.8	8	19.1	M4	22.9	5	6.5	5°	0.127	2.5	50	15
R3006.D04-05	2.8	5	19.1	M4	22.9	4	6.5	5°	0.127	2.5	50	15
R3006.D04-06	2.8	6	19.1	M4	22.9	4	6.5	5°	0.127	2.5	50	15
R3006.D04-08	2.8	8	19.1	M4	22.9	4	6.5	5°	0.127	2.5	50	15
R3006.D05-05	2.8	5	19.1	M4	22.9	5	6.5	5°	0.127	2.5	50	15
R3006.D05-06	2.8	6	19.1	M4	22.9	5	6.5	5°	0.127	2.5	50	15
R3006.D05-08	2.8	8	19.1	M4	22.9	5	6.5	5°	0.127	2.5	50	15
R3006.D06-06	2.8	8	19.1	M4	22.9	5	6.5	5°	0.127	2.5	50	15
R3006.D06-08	2.8	8	19.1	M4	22.9	5	6.5	5°	0.127	2.5	50	15
R3006.D08-08	2.8	8	19.1	M4	22.9	5	6.5	5°	0.127	2.5	50	15
R3006.E05-06	4.8	6	25.4	M5	31.8	5	9	5°	0.127	4	104	40
R3006.E05-08	4.8	8	25.4	M5	31.8	5	9	5°	0.127	4	104	40
R3006.E05-10	4.8	10	25.4	M5	31.8	5	9	5°	0.127	4	104	40
R3006.E06-06	4.8	6	25.4	M5	31.8	6	9	5°	0.127	4	104	40
R3006.E06-08	4.8	8	25.4	M5	31.8	6	9	5°	0.127	4	104	40
R3006.E06-10	4.8	10	25.4	M5	31.8	6	9	5°	0.127	4	104	40
R3006.E08-08	4.8	8	25.4	M5	31.8	8	9	5°	0.127	4	104	40
R3006.E08-10	4.8	10	25.4	M5	31.8	8	9	5°	0.127	4	104	40
R3006.E10-10	4.8	10	25.4	M5	31.8	10	9	5°	0.127	4	104	40