

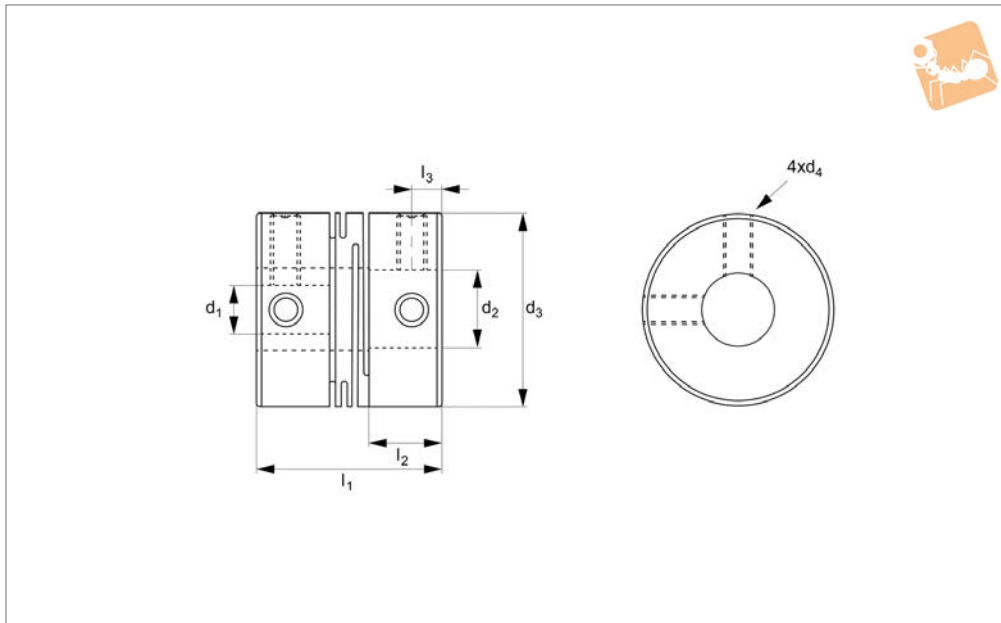

Beamed Coupling - three beam

stainless steel, clamp type

Flexible Couplings

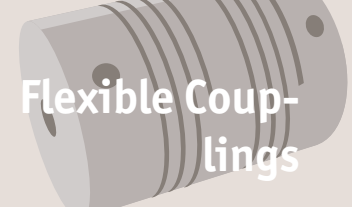

R3009

FLEXIBLE COUPLINGS

Material

Stainless steel 1.4435 (AISI 316L)

Technical Notes

One piece construction, no mechanical joints.

No backlash.

Constant velocity.

Torsionally rigid.

High flexibility.

Temperature range -40°C to +120°C.

Central relief diameter may be smaller than

bore in some cases.

Max Torque:

Select the size where max.torque exceeds the application target service factor.

Service Factors:

Shock + reversing = 2

Non reversing = 1,5

Steady load = 1

Max. rpm = 5,000

Torsional stiffness:

based on - bore diameter of minimum D_2 for size at load of (max torque/2).

Tips

Suitable for:

encoders, stepper motors, precision ball screws, robotics, scientific equipment, measuring systems, medical systems, pumps, servo systems etc.

Order No.	d ₁	d ₂	d ₃	d ₄	l ₁	l ₂	n	Ang. offset	Par. offset mm	Torque Nm max.	Tors. stiffness Nm/rad	Weight g
R3009.A02-03	1.9	3	9.5	-	14.2	2	4.5	3°	0.1	0.4	4	5
R3009.A02-04	1.9	4	9.5	-	14.2	2	4.5	3°	0.1	0.4	4	5
R3009.A03-03	1.9	3	9.5	-	14.2	3	4.5	3°	0.1	0.4	4	5
R3009.A03-04	1.9	4	9.5	-	14.2	3	4.5	3°	0.1	0.4	4	5
R3009.A04-04	1.9	4	9.5	-	14.2	4	4.5	3°	0.1	0.4	4	5
R3009.B03-04	2.8	4	12.7	M2	19.1	3	6	5°	0.127	1.0	63	13
R3009.B03-05	2.8	5	12.7	M2	19.1	3	6	5°	0.127	1.0	63	13
R3009.B04-04	2.8	4	12.7	M2	19.1	4	6	5°	0.127	1.0	63	13
R3009.B04-05	2.8	5	12.7	M	19.1	4	6	5°	0.127	1.0	63	13
R3009.B04-06	2.8	6	12.7	M2	19.1	4	6	5°	0.127	1.0	63	13
R3009.B05-05	2.8	5	12.7	M2	19.1	5	6	5°	0.127	1.0	63	13
R3009.C03-04	2.8	4	15.9	M2,5	20.3	3	6.0	5°	0.127	1.8	100	21
R3009.C03-05	2.8	5	15.9	M2,5	20.3	3	6.0	5°	0.127	1.8	100	21
R3009.C03-06	2.8	6	15.9	M2,5	20.3	3	6.0	5°	0.127	1.8	100	21
R3009.C04-04	2.8	4	15.9	M2,5	20.3	4	6.0	5°	0.127	1.8	100	21
R3009.C04-05	2.8	5	15.9	M2,5	20.3	4	6.0	5°	0.127	1.8	100	21
R3009.C04-06	2.8	6	15.9	M2,5	20.3	4	6.0	5°	0.127	1.8	100	21
R3009.C05-04	2.8	4	15.9	M2,5	20.3	5	6.0	5°	0.127	1.8	100	21
R3009.C05-05	2.8	5	15.9	M2,5	20.3	5	6.0	5°	0.127	1.8	100	21
R3009.C05-06	2.8	6	15.9	M2,5	20.3	5	6.0	5°	0.127	1.8	100	21
R3009.C06-06	2.8	6	15.9	M2,5	20.3	6	6.0	5°	0.127	1.8	100	21
R3009.D03-05	2.8	5	19.1	M2,5	22.9	3	6.5	5°	0.127	2.7	80	40
R3009.D03-06	2.8	6	19.1	M2,5	22.9	3	6.5	5°	0.127	2.7	80	40
R3009.D03-08	2.8	8	19.1	M2,5	22.9	3	6.5	5°	0.127	2.7	80	40



Order No.	d ₁	d ₂	d ₃	d ₄	l ₁	l ₂	n	Ang. offset	Par. offset mm	Torque Nm max.	Tors. stiffness Nm/rad	Weight g
R3009.D04-05	2.8	5	19.1	M2,5	22.9	4	6.5	5°	0.127	2.7	80	40
R3009.D04-06	2.8	6	19.1	M2,5	22.9	4	6.5	5°	0.127	2.7	80	40
R3009.D04-08	2.8	8	19.1	M2,5	22.9	4	6.5	5°	0.127	2.7	80	40
R3009.D05-05	2.8	5	19.1	M2,5	22.9	5	6.5	5°	0.127	2.7	80	40
R3009.D05-06	2.8	6	19.1	M2,5	22.9	5	6.5	5°	0.127	2.7	80	40
R3009.D05-08	2.8	8	19.1	M2,5	22.9	5	6.5	5°	0.127	2.7	80	40
R3009.D06-06	2.8	6	19.1	M2,5	22.9	6	6.5	5°	0.127	2.7	80	40
R3009.D06-08	2.8	8	19.1	M2,5	22.9	6	6.5	5°	0.127	2.7	80	40
R3009.D08-08	2.8	8	19.1	M2,5	22.9	8	6.5	5°	0.127	2.7	80	40
R3009.E05-06	4.8	6	25.4	M3	31.8	5	9.0	5°	0.127	6.0	163	106
R3009.E05-08	4.8	8	25.4	M3	31.8	5	9.0	5°	0.127	6.0	163	106
R3009.E05-10	4.8	10	25.4	M3	31.8	5	9.0	5°	0.127	6.0	163	106
R3009.E06-06	4.8	6	25.4	M3	31.8	6	9.0	5°	0.127	6.0	163	106
R3009.E06-08	4.8	8	25.4	M3	31.8	6	9.0	5°	0.127	6.0	163	106
R3009.E06-10	4.8	10	25.4	M3	31.8	6	9.0	5°	0.127	6.0	163	106
R3009.E08-08	4.8	8	25.4	M3	31.8	8	9.0	5°	0.127	6.0	163	106
R3009.E08-10	4.8	10	25.4	M3	31.8	8	9.0	5°	0.127	6.0	163	106
R3009.E10-10	4.8	10	25.4	M3	31.8	10	9.0	5°	0.127	6.0	163	106