

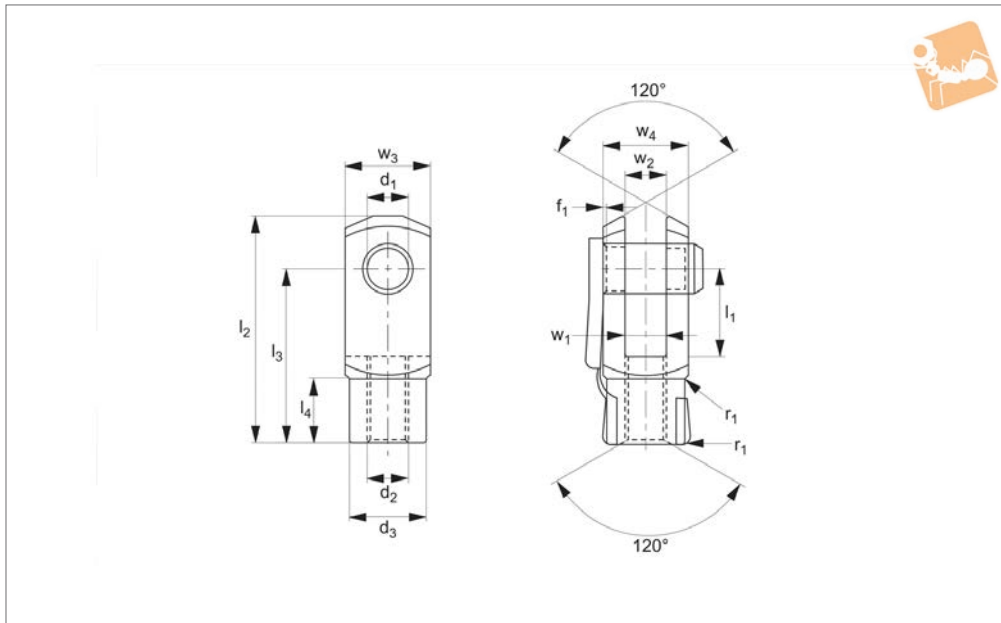

Steel Clevis Joints with Retention

silver zinc plated

Clevis Joints & Clips



R3387

CLEVIS JOINTS & CLIPS

Material

Steel 1.0718 (11SMnPb30k), silver zinc plated.

Technical Notes

M4-M16: DIN 71 752/DIN ISO 8140.
M20: Similar to DIN 71 752/DIN ISO 8140 and according to CETOP standard.

Tips

For yellow zinc plated version see R3398, standard thread is right hand, (for left hand, see R3388).

Assembly made up using R3385 clevis joint and R3435 clevis retention clip.

Important Notes

For sizes M4-M12, f_1 and $r_1 = 0,5$, for sizes M14-M16, f_1 and $r_1 = 1$
For sizes M18-M20, $f_1 = 1$, $r_1 = 1,5$, for M24 f_1 and $r_1 = 1,5$, for sizes M27-M30, $f_1 = 1,5$, $r_1 = 2$
For M36 $f_1 = 2$, $r_1 = 3$, for sizes M42-M48, $f_1 = 3$, $r_1 = 5$, for r_1 , radius or 45° bevelling.
Other Tolerances:-

w_4 : M4-M16 = +0,3 -0,16
M18-M48 = +0,5 -0,2
 w_2 : size 4x8-10x20 = B13
All others +0,7 +0,15
 d_3 : M4-M16 = ±0,3
 l_2 : size 4x8-6x12 = ±0,3
All others ±0,4
 l_3 : M4-M16 = ±0,2
M18-M48 = ±0,3
 r_1 : M18-M48 = ±0,5

Order No.	Size	Thread hand	Thread type	d_1 tol. H9	l_1 ±0.5	d_2	d_3	l_2 ±0.5	l_3	l_4	w_1 tol. B13	w_2	w_3 tol. h11	w_4	Weight g
R3387.R040	4x8	Right	Coarse	4	8	M4	8	21	16	6.0	4	4	8	8	5
R3387.R051	5x10	Right	Coarse	5	10	M5	9	26	20	7.5	5	5	10	10	9
R3387.R052	5x20	Right	Coarse	5	20	M5	9	36	30	7.5	5	5	10	10	13
R3387.R061	6x12	Right	Coarse	6	12	M6	10	31	24	9.0	6	6	12	12	15
R3387.R062	6x24	Right	Coarse	6	24	M6	10	43	36	9.0	6	6	12	12	21
R3387.R081	8x16	Right	Coarse	8	16	M8	14	42	32	12.0	8	8	16	16	37
R3387.R082	8x16	Right	Fine	8	16	M8x1	14	42	32	12.0	8	8	16	16	37
R3387.R083	8x32	Right	Coarse	8	32	M8	14	58	48	12.0	8	8	16	16	54
R3387.R084	8x32	Right	Fine	8	32	M8x1	14	58	48	12.0	8	8	16	16	54
R3387.R102	10x20	Right	Coarse	10	20	M10	18	52	40	15.0	10	10	20	20	74
R3387.R103	10x20	Right	Fine	10	20	M10x1,25	18	52	40	15.0	10	10	20	20	74
R3387.R104	10x40	Right	Coarse	10	40	M10	18	72	60	15.0	10	10	20	20	116
R3387.R105	10x40	Right	Fine	10	40	M10x1,25	18	72	60	15.0	10	10	20	20	116
R3387.R122	12x24	Right	Coarse	12	24	M12	20	62	48	18.0	12	12	24	24	121
R3387.R123	12x24	Right	Fine	12	24	M12x1,25	20	62	48	18.0	12	12	24	24	121
R3387.R124	12x48	Right	Coarse	12	48	M12	20	86	72	18.0	12	12	24	24	175
R3387.R125	12x48	Right	Fine	12	48	M12x1,25	20	86	72	18.0	12	12	24	24	175
R3387.R142	14x28	Right	Coarse	14	28	M14	24	72	56	22.5	14	14	27	27	178
R3387.R143	14x28	Right	Fine	14	28	M14x1,5	24	72	56	22.5	14	14	27	27	178
R3387.R145	14x56	Right	Coarse	14	56	M14	24	101	85	22.5	14	14	27	27	258
R3387.R146	14x56	Right	Fine	14	56	M14x1,5	24	101	85	22.5	14	14	27	27	258
R3387.R163	16x32	Right	Coarse	16	32	M16	26	83	64	24.0	16	16	32	32	282
R3387.R164	16x32	Right	Fine	16	32	M16x1,5	26	83	64	24.0	16	16	32	32	282
R3387.R166	16x64	Right	Coarse	16	64	M16	26	115	96	24.0	16	16	32	32	411
R3387.R167	16x64	Right	Fine	16	64	M16x1,5	26	115	96	24.0	16	16	32	32	411



Order No.	Size	Thread hand	Thread type	d ₁ tol. H9	l ₁ ±0.5	d ₂	d ₃	l ₂ ±0.5	l ₃	l ₄	w ₁ tol. B13	w ₂	w ₃ tol. h11	w ₄	Weight g
R3387.R204	20x40	Right	Coarse	20	40	M20	34	105	80	30.0	20	20	40	40	550
R3387.R205	20x40	Right	Fine	20	40	M20x1,5	34	105	80	30.0	20	20	40	40	550



Parts overview

Clevis Joints

Stocked to DIN 71752 in steel and stainless steel. Plain clevis joints available in right and left hand threads zinc plated steel and stainless steel. Steel sizes from M4 up to M48. Stainless sizes from M4 up to M27.



Clevis Mating Pieces

These are designed to fit in between our clevis joints to create a linkage where an angular offset is required. Available in zinc plated steel and stainless steel. Sizes M4 up to M20.



Clevis Pins and Clips

Various styles of pins and clips to suit clevis joints in zinc plated steel and stainless steel. Sizes available to suit all sizes of clevis joints that we offer.



Clevis Retention Clips

These are the most popular type of clip used with our clevis joints. They create a neat compact assembly, only available in zinc plated steel. Size available for clevis joints from 4mm up to 20mm.



Male Clevis Joints

Stocked in zinc plated steel and stainless steel, right and left hand threads. Sizes M6 up to M20.





Zinc plated steel

Clevis with retention clip
65630 and 65684



Clevis with clevis pin 65664
Safety fastener 65680

Clevis with clevis pin,
washer and cotter pin
65660 and 65674



Stainless steel

Clevis with clevis pin
and circlips 65666
and 65678



Clevis with clevis pin,
washer and cotter pin
65661 and 65675



Assembly options

Clevis with 65652
mating piece
and 65684 clevis
retention clip



Clevis with 65880
rod end and 65684
clevis retention clip



Tensile tests, statistically to failure (break)

Clevises M6 - M42

Clevis joints axially loaded.

Material

Leaded low carbon steel (AISI 12L14, 1.0718).

Important note: values in this table are indicative only and should only be used as a rough guide. The Company cannot foresee the intended applications of their products and we accept no liability for any actions taken by third parties. Customers are advised to use their own safety factors and/or perform their own testing on the clevis joint to ensure it meets requirements for their application.

Clevis size	F min (kN)	F max (kN)	F average value (kN)	Avg. force when clevis starts to deform (kN)
6 x 24 M 6	16,0	19,5	17,6	15,3
8 x 32 M 8	33,2	35,6	34,6	29,3
10 x 40 M10	42,0	52,0	47,5	41,3
12 x 48 M12	53,0	68,5	61,1	50,2
14 x 56 M14	60,5	64,5	63,0	48,8
16 x 64 M16	133,5	146,0	140,2	115
20 x 40 M20	194,5	234,0	213,5	176
25 x 50 M25	311,0	336,0	328,0	260
30 x 60 M30	428,0	450,0	440,6	343
36 x 72 M36	566,0	573,0	569,5	300
35 x 72 M36	561,2	567,9	564,6	370
42 x 84 M42	904,6	904,6	904,6	420