

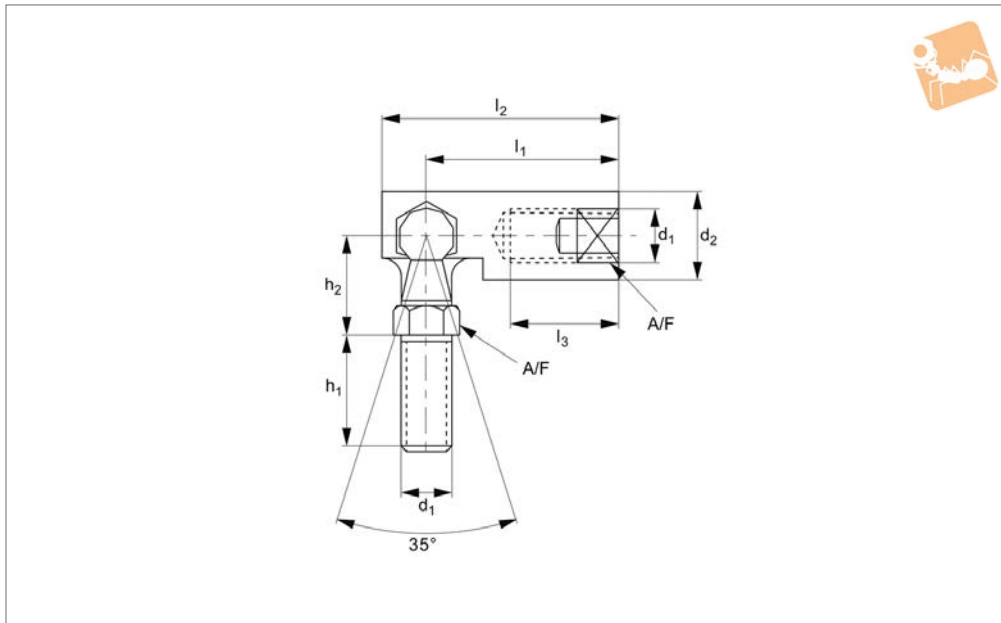

Ball and Socket Joints

Imperial (DIG)

Ball & Socket Joints



R3530.i

BALL & SOCKET JOINTS

Material

Yellow zinc plated steel, ball stud is case hardened.

Technical Notes

The swaging of the body produces a permanent assembly and the fitted sealing cap helps resist dirt ingress.

The hexagon form of studs facilitates assembly, yellow zinc is not RoHS Compliant.

Tips

Standard Thread is Right hand thread, equivalent to Springfix DIG joints.

Order No.	Thread hand	d ₁	d ₂	l ₁	l ₂	h ₁	h ₂	l ₃	A/F
R3530.I187	Right	10-32	0.375	0.875	1.063	0.438	0.438	0.438	0.313
R3530.I250	Right	1/4-28	0.438	0.969	1.219	0.563	0.469	0.500	0.375
R3530.I312	Right	5/16-24	0.500	1.125	1.406	0.688	0.531	0.563	0.438
R3530.I375	Right	3/8-24	0.625	1.375	1.688	0.875	0.688	0.750	0.500
R3530.I438	Right	7/16-20	0.750	1.938	2.375	1.125	0.875	1.000	0.625
R3530.I500	Right	1/2-20	0.750	1.938	2.375	1.125	0.875	1.000	0.625
R3530.I625	Right	5/8-18	0.875	2.063	2.578	1.125	1.000	1.000	0.750
R3530.IL187	Left	10-32 LH	0.375	0.875	1.063	0.438	0.438	0.438	0.313
R3530.IL250	Left	1/4-28 LH	0.438	0.969	1.219	0.563	0.469	0.500	0.375
R3530.IL312	Left	5/16-24 LH	0.500	1.125	1.406	0.688	0.531	0.563	0.438
R3530.IL375	Left	3/8-24 LH	0.625	1.375	1.688	0.875	0.688	0.750	0.500
R3530.IL438	Left	7/16-20 LH	0.750	1.938	2.375	1.125	0.875	1.000	0.625
R3530.IL500	Left	1/2-20 LH	0.750	1.938	2.375	1.125	0.875	1.000	0.625
R3530.IL625	Left	5/8-18 LH	0.875	2.063	2.578	1.125	1.000	1.000	0.750