

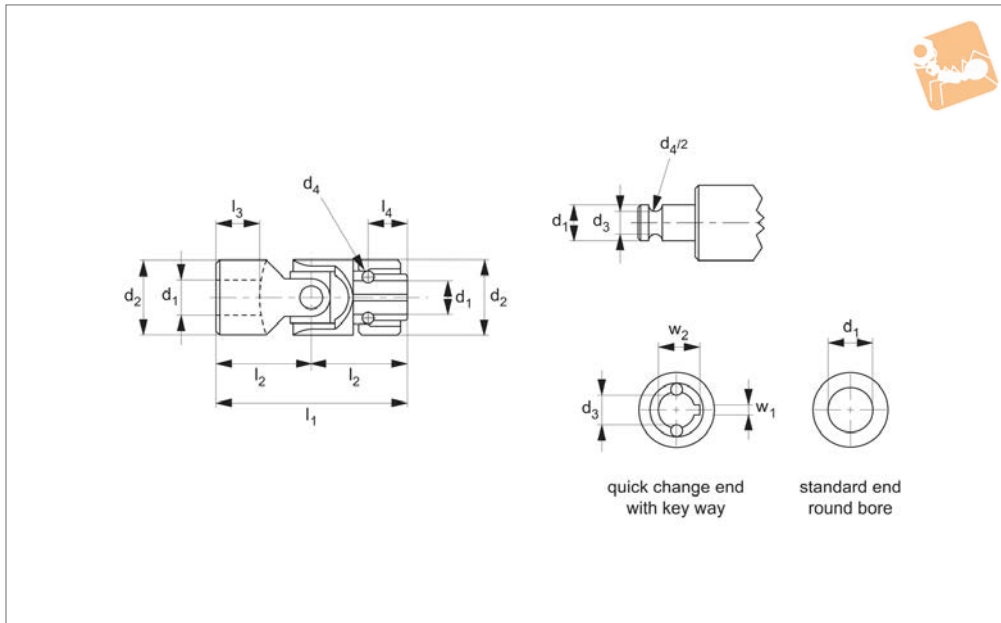

Universal Joint with quick change coupling

Universal Joints



R3693

UNIVERSAL JOINTS

Material

Steel (9 SMnPb28 k, no. 10718, greased).
Bearing type: plain bearing.

Technical Notes

To DIN 808.
Maximum bending angle 45° per joint.
Max. drive speed of joints with journal

bearings 1000 rpm.

Tips

Rapid change coupling ideal where time is critical.
Retention of shaft accomplished with two ball bearings engaging the shaft via a round bore with keyway.

Product variations available on request: needle bearings and hex shaped bores. (Keyway and hex shaped bores on quick change end only unless requested otherwise.)

Order No.	d ₁ tol. H7	d ₂	d ₃	d ₄	l ₁	l ₂	l ₃	l ₄	w ₁ tol. JS9	w ₂	Weight g
R3693.010	10	22	8.7	4	62	31	17	11.5	3	11	100
R3693.012	12	25	11	4	74	37	21	13.5	4	13.3	160
R3693.014	14	25	13	4	74	37	21	13.5	5	15.3	160
R3693.016	16	32	14.8	6.35	86	43	24	14	5	17.3	310
R3693.018	18	36	16	8	96	48	28	19	6	19.8	460
R3693.020	20	42	18	8	108	54	31	19	6	22.8	610
R3693.022	22	45	20	10	120	60	34	20.5	6	24.8	960
R3693.025	25	50	23	10	132	66	38	20.5	8	28.3	1150
R3693.030	30	58	28	10	166	83	49	25	8	33.3	2080



When one single joint is coupled with two shafts (of which the driving one is rotating at a constant speed) forming an angle, a periodic variation of the driven shaft is caused with exactly four fluctuations per revolution.

The difference between the maximum and the minimum speed of the driven shaft depends on the angle formed by the two shafts. The difference grows with the increase of the angle a° . To have a smooth transmission, either two opposite single joints (ensuring that the two central yokes lie on the same plane and the angles are equal) or a double joint need to be fitted. The irregularity caused by the articulation of the first unisex joint is cancelled by the second unisex joint. The overall length resulting from the coupling of the two single joints can be reduced by using a double unisex joint. In other words, the double joint is to be considered as the shortest method of achieving smooth transmission.

For low speed applications (max. 1000 rpm), joints with plain bearings are recommended. They are able to support shock loads, motion reversal, irregular running and relatively high torques. The working angles must be restricted when using at speeds between 500 - 1000 rpm. Please consult our technical department if you have such an application.

For high rotation speeds, relatively low torques or wide angles, joints with needle roller bearings are preferred. They can reach 4000 rpm dependent on the angle.

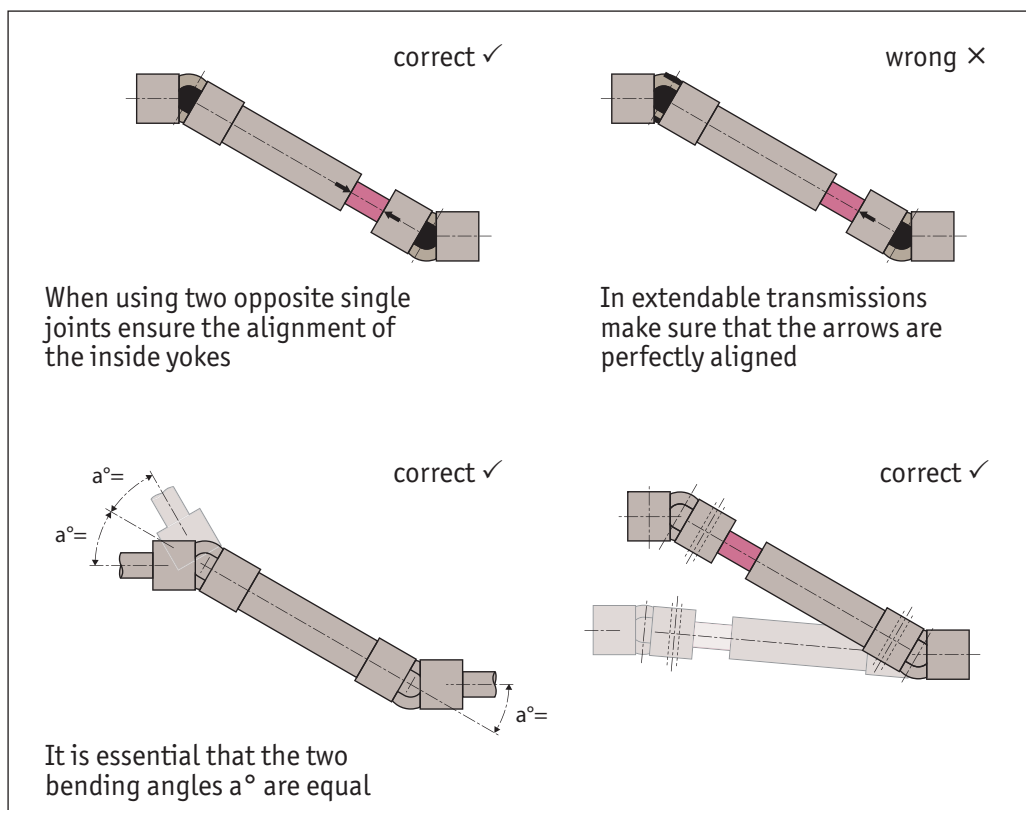
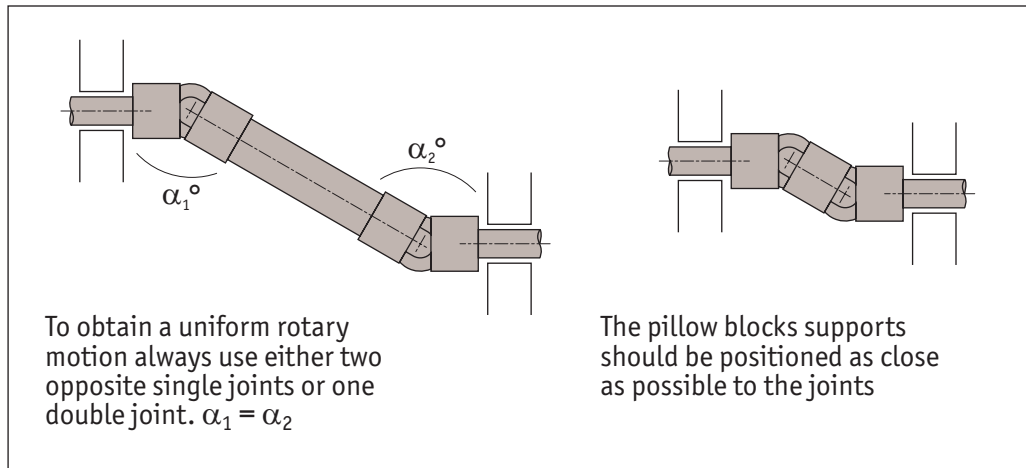



How to read diagrams

The joints capacity to transmit a regular torque at a constant load with no shocks, for a long period, mainly depends on the number of revolutions per minute and the inclination angle a° of the two axes. The diagrams on the following pages are based on this. Each curve corresponds to the joint size (outside diameter "D") and represents the torque that the joint can transmit depending on speed and working angle a° .

The diagrams can be directly read if angle (a°) is 10° . For wider angles, torques are reduced, these should be corrected using the correction vales (F) relating to the angle shown in the table.

IMPORTANT

Graph values are merely indicative and refer to the single joints only. When choosing a double joint, you have to consider that they can transmit a torque about 10% lower than the same sized single joints. Each application has its own particular motion characteristics, such as: shock loads, motion reversals, connected masses, kind of starting, presence of elastic joints, stops and starts, etc., that have to be considered when choosing the joint.

Working angle a°	Correction value F
5°	1,25
10°	1,00
15°	0,80
20°	0,65
25°	0,55
30°	0,45
35°	0,38
40°	0,30
45°	0,25

Torque Calculation for Plain Bearings

Power: 0,65 KW, RPM: 230

With working angle 10° Value F = 1 we get point P. Torque = 27 Nm corresponding to joint size "D" = 25/26mm. = Types R3688.016 and R3689.012

With working angle 30° Value F = 0.45 (Kw 0,65: 0,45 = 1,44Kw) we get point P1 Torque = 60 Nm corresponding to joint size "D" = 32mm. = Types R3688.020 and R3689.016

Consider that:

$$\text{Torque in Nm} = 9550 \times \frac{\text{Power (KW)}}{\text{RPM}}$$

$$\text{Torque in Nm} = 7020 \times \frac{\text{Power (HP)}}{\text{RPM}}$$

Note: 1 KW = 1,35 HP and HP = 0,736 KW

Note: 1 Kgm = 9,81 Nm and Nm = 0,102 Kgm



Plain Bearings Single & Double

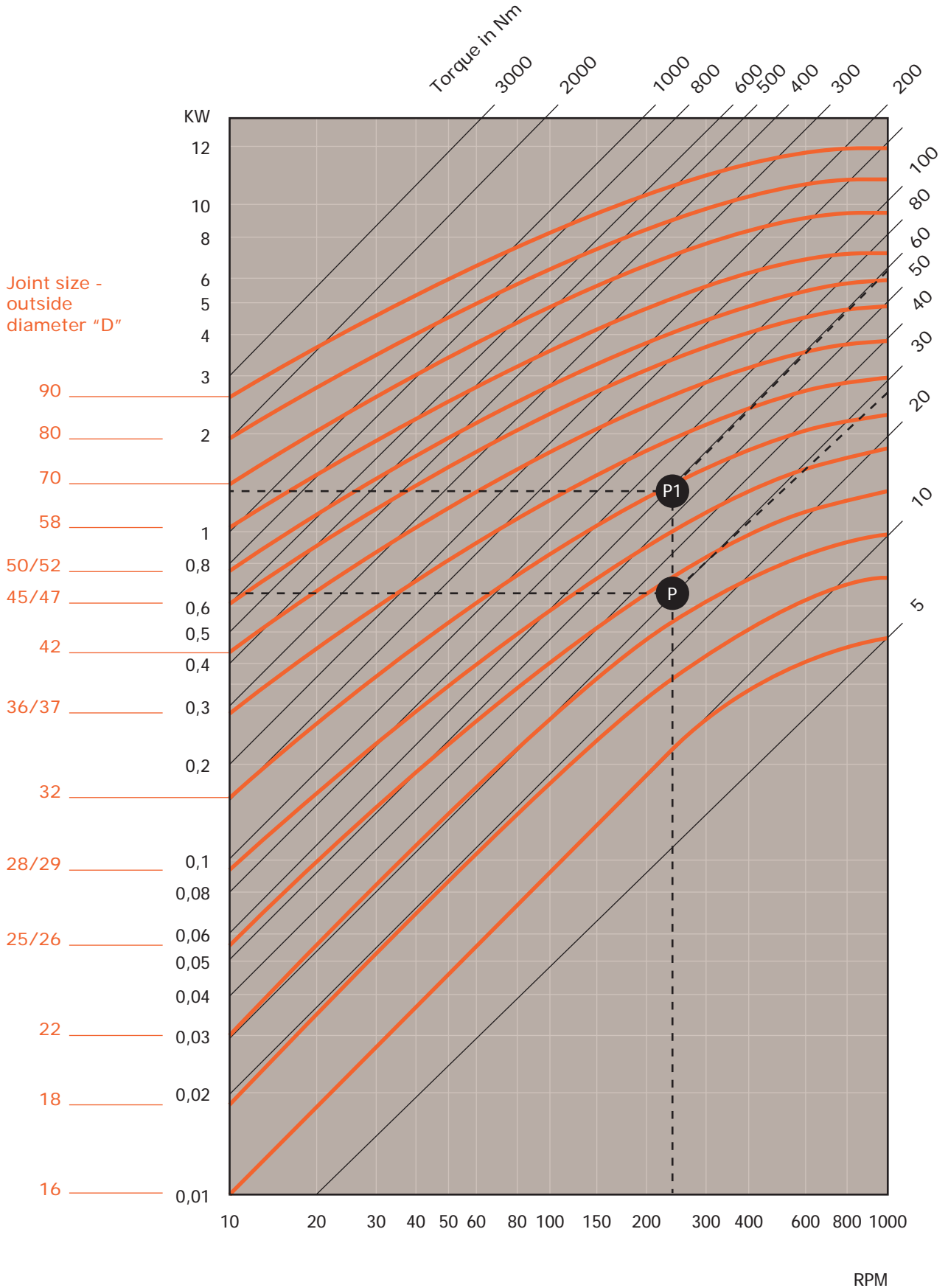

*For double reduce Torque by 15%

Working angle a °	Correction value F
5°	1,25
10°	1,00
15°	0,90
20°	0,80
25°	0,70
30°	0,50
35°	0,40
40°	0,30
45°	0,25

Torque Calculation

Power: 0,55 KW, RPM: 2300

With working angle a 10° Value F = 1 we get point P. Torque = 23 Nm corresponding to joint size "D" = 28mm. = Type R3686.014

With working angle a 25° Value F = 0.70 (Kw 5,5: 0,70 = 7,85Kw) we get point P1 Torque = 33 Nm corresponding to joint size "D" = 32mm. = Type R3686.016

Consider that:

$$\text{Torque in Nm} = 9550 \times \frac{\text{Power (KW)}}{\text{RPM}}$$

$$\text{Torque in Nm} = 7020 \times \frac{\text{Power (HP)}}{\text{RPM}}$$

Note: 1 KW = 1,35 HP and HP = 0,736 KW

Note: 1 Kgm = 9,81 Nm and 1Nm = 0,102 Kgm

Factor in a safety factor for shock load, recipricating methods, start up shocks etc.

Universal Joints from Automation Components

UNIVERSAL JOINTS